



Llywodraeth Cynulliad Cymru  
Welsh Assembly Government

**Code of Practice**  
January 2008



# **New Roads and Street Works Act 1991**

**Code of Practice for the  
Co-ordination of Street  
Works and Works for  
Road Purposes and  
Related Matters**

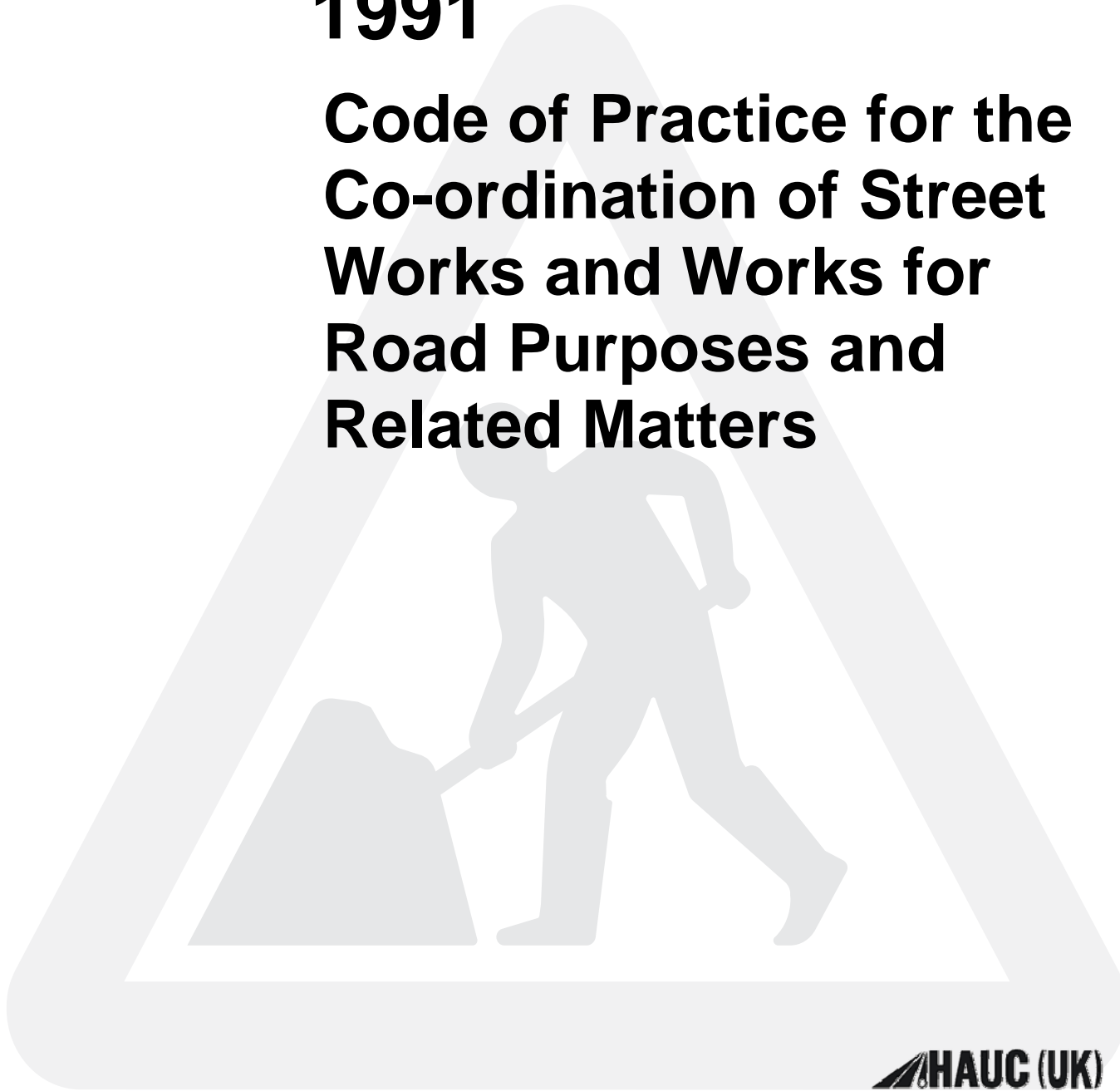

**HAUC (UK)**  
HIGHWAY AUTHORITIES & UTILITIES COMMITTEE

## Summary Reference Guide

Table 1. Matrix of notice periods and response times							
	Notice Period		Validity Period		Response Time		
	S 54	Ss 55/57	S 54	Ss 55/57	S54	Ss55/57	S 74
<b>Major</b>	3 months	10 days	15days	5 days	1 month	5 days	5 days
<b>Standard</b>	n/a	10 days	n/a	5 days	n/a	5 days	5 days
<b>Minor</b>	n/a	3 days	n/a	2 days	n/a	2 days	2 days
<b>Immediate</b>	n/a	2 hours after	n/a	n/a	n/a	any time during works	2 days

Sections of NRSWA covered in this guidance:

48	Streets, street works and undertakers
49	The street authority and other relevant authorities
50	Street works licences
52	Emergency works
53	The street works register
54	Advance notice of certain works
55	Notice of starting date of works
56	Power to give directions as to the timing of street works
56A	Power to give directions as to placing of apparatus
57	Notice of emergency works
58	Restriction on works following substantial road works
58A	Restriction on works following substantial street works
59	General duty of street authority to co-ordinate works
60	General duty of undertakers to co-operate
61	Protected streets
62	Supplementary provisions as to designation of protected streets
63	Streets with special engineering difficulties
64	Traffic-sensitive streets
66	Avoidance of unnecessary delay or obstruction
70	Duty of undertaker to reinstate
72	Powers of street authority in relation to reinstatement
74	Charge for occupation of the highway where works are unreasonably prolonged
76	Liability for cost of temporary traffic regulation
81	Duty to maintain apparatus
83	Apparatus affected by highway, bridge or transport works
87	Prospectively maintainable highways
88	Bridges, bridge authorities and related matters
91	Transport authorities, transport undertakings and related matters
95	Offences
95A	Fixed Penalty Notices
97	Service of notices and other documents
98	Reckoning of periods
99	Arbitration

# **New Roads and Street Works Act 1991**

**(2008 No.4)**

## **Code of Practice for the Co-ordination of Street Works and Works for Road Purposes and Related Matters**

***Approved by the Welsh Ministers under sections 56, 56A, 59 and  
60 of the Act***

January 2008

Transport Wales  
Welsh Assembly Government  
Cathays Park  
Cardiff CF10 3NQ  
Telephone 02920 826456  
Web site [www.new.wales.gov.uk](http://www.new.wales.gov.uk)

© Crown copyright, 2008, except where otherwise stated

Copyright in the typographical arrangement rests with the Crown.

This publication, excluding logos, may be reproduced free of charge in any format or medium for non-commercial research, private study or for internal circulation within an organisation. This is subject to it being reproduced accurately and not used in a misleading context. The copyright source of the material must be acknowledged and the title of the publication specified.

For any other use of this material, apply for a Click-Use Licence at [www.opsi.gov.uk/click-use/index.htm](http://www.opsi.gov.uk/click-use/index.htm), or by writing to the Licensing Division, Office of Public Sector Information, St Clements House, 2–16 Colegate, Norwich NR3 1BQ, fax 01603 723000, e-mail [licensing@opsi.x.gsi.gov.uk](mailto:licensing@opsi.x.gsi.gov.uk)

## FOREWORD

The New Roads and Street Works Act 1991 (NRSWA), supported by relevant Regulations and Codes of Practice, provides a legislative framework for street works by undertakers (including utility companies) and works for road purposes - to the extent that these must be co-ordinated by street authorities.

The aim is to balance the statutory rights of highway authorities and undertakers to carry out works with the right of road users to expect the minimum disruption from works.

The Welsh Ministers have approved this code under the powers to approve or issue codes of practice in the following sections of NRSWA:

- Section 56(4) - the power of authorities to give directions as to the timing of street works
- Section 56A(8) - the power of authorities to give directions as to the placing of apparatus
- Section 59(3) - the duty of street authorities to co-ordinate works
- Section 60(2) - the duty of undertakers to co-operate with street authorities and with other undertakers.

The Code reflects various changes made to the provisions of NRSWA under the Traffic Management Act 2004 (TMA). The TMA tightens the regulatory framework within which undertakers dig up roads, giving authorities more power to co-ordinate, control and direct works effectively with the aim of minimising disruption.

The Code also incorporates the requirements set out in the following regulations:

- The Street Works (Registers, Notices, Directions and Designations) (Wales) Regulations 2008, SI 2008 No.101 (W.14);
- The Street Works (Charges for Prolonged Occupation of the Highway) (Wales) Regulations 2008, SI [X], No. [X]; *Regulations to follow later this year.*
- The Street Works (Fixed Penalty) (Wales) Regulations 2008, SI 2008 No.102 (W.15);
- The Street Works (Registration Fees) (Regulations) 1999, SI 1999, No. 1048.

Practical guidance is given on undertakers' and authorities' responsibilities with regard to street or highway works. The relevant sections of NRSWA are listed on page 2.

This Code was prepared by several working parties comprising representatives of the Department for Transport, Transport Wales, the National Joint Utilities Group and local highway authorities and was the subject of extensive consultation with relevant organisations.

Street works are a devolved matter in Wales. This 2<sup>nd</sup> edition of the Code has been approved by the Welsh Ministers for use in Wales **only**. It replaces the 1<sup>st</sup> edition

published in November 1992 and comes into operation on 1st April 2008.

# CONTENTS

<b>1. INTRODUCTION</b>	<b>7</b>
<b>2. CO-ORDINATION IN PRACTICE</b>	
2.1 Introduction	12
2.2 Information	13
2.3 Analysis	15
2.4 Consideration	16
2.5 Co-operation	16
2.6 Forward Planning	17
2.7 Collaborative Working	18
2.8 Reinstatements	19
2.9 Phasing of Works	19
2.10 Interrupted Works	20
2.11 Key Performance Indicators (KPIs)	20
<b>3. THE REGISTER</b>	
3.1 Introduction	22
3.2 Register Keepers	22
3.3 Local and Central Registers	22
3.4 Form of Registers	22
3.5 Content of Registers	23
3.6 Access to Registered Information	24
<b>4. THE STREET GAZETTEER AND ADDITIONAL STREET DATA</b>	
4.1 Introduction	27
4.2 The Street Gazetteer	27
4.3 Additional Street Data	28
<b>5. STREETS SUBJECT TO SPECIAL CONTROLS</b>	
5.1 Introduction	30
5.2 Protected Streets	30
5.3 Streets with Special Engineering Difficulties	31
5.4 Traffic-Sensitive Streets	34
5.5 Procedure for making designations	35
5.6 Procedure for withdrawing designations	36
5.7 Other Features of the Street	36
<b>6. RESTRICTIONS</b>	
6.1 Introduction	39
6.2 Substantial Works - Definitions	39
6.3 Creating a Restriction	39
6.4 Duration of Restrictions	41
6.5 Works during a Restriction	42
6.6 Policy Guidance	43
6.7 Dispute Resolution	44

<b>7.</b>	<b>WORKS CLASSIFICATIONS</b>	
7.1	Works Promoters	45
7.2	Street Works Licences	45
7.3	Registerable Works	46
7.4	Street Authority Works for Road Purposes	47
7.5	Works Types	48
7.6	Remedial Works	51
<b>8.</b>	<b>NOTICE REQUIREMENTS AND VALIDITY</b>	
8.1	Introduction	52
8.2	Notice Types	52
8.3	General rules applying to all notices	56
8.4	Notice Validity	60
<b>9.</b>	<b>DIRECTIONS</b>	
9.1	Introduction	63
9.2	Section 56 Directions	63
9.3	Section 56A Directions	64
9.4	Revocation of Directions	65
9.5	Street Authority Responses	65
9.6	Section 66 Notices	66
<b>10.</b>	<b>[Not used - reserved]</b>	
<b>11.</b>	<b>FIXED PENALTY NOTICES</b>	
11.1	Introduction	68
11.2	Fixed Penalty Offences under part 3 of NRSWA	68
11.3	Time Periods	71
11.4	Guidance for the Street Authority	72
11.5	Guidance for Undertakers	76
11.6	Representations	77
11.7	Application of money by Street Authorities	77
<b>12.</b>	<b>RELATED MATTERS</b>	
12.1	Road Closures and Traffic Restrictions	78
12.2	Maintenance of undertakers' apparatus	80
12.3	Working near rail tracks and Tramways	82
12.4	Vehicle Parking at Street and Road Works	82
12.5	Storing Materials	83
12.6	Apparatus belonging to others	83
12.7	Assessing the Impact of Works	83
12.8	Environmental Issues	84
<b>13.</b>	<b>DISPUTE RESOLUTION</b>	
13.1	Introduction	85
13.2	Appeals Procedure	85
13.3	Dispute review	85
13.4	Adjudication	86
13.5	Arbitration	86



<b>Appendix A: GLOSSARY</b>	<b>88</b>
<b>Appendix B: TRANSITIONAL ARRANGEMENTS</b>	
B.1 Introduction	96
B.2 Principle	96
B.3 Notices of planned works (s54 and s55)	96
B.4 Directions	98
B.5 Restrictions following substantial road or street works	98
B.6 Reinstatements	98
B.7 EToN protocols	98
B.8 End date for existing EToN system	98
B.9 Street Gazetteers and Additional Street Data	99
B.10 Organisational Data	99
B.11 Fixed Penalty Notices	99
B.12 [Charges for Prolonged Occupation of the Highway (s74 charges)	
B.13 S74 charges for Remedial Works - Not Used]	
<b>Appendix C: WORKS AT OR NEAR LEVEL CROSSINGS</b>	<b>100</b>
<b>Appendix D: WORKS NEAR HIGHWAY STRUCTURES</b>	<b>110</b>
<b>Appendix E: CO-ORDINATION SCHEDULES</b>	<b>128</b>
<b>Appendix F: CENTRAL REGISTERS</b>	<b>129</b>
<b>Appendix G: DERIVATION OF DISRUPTION EFFECT SCORE</b>	<b>130</b>
<b>Appendix H: FIXED PENALTY NOTICES FORMS</b>	<b>133</b>
<b>Separate publication</b>	
<b>Technical Specification for the Electronic Transfer of Notices (EToN v 4.0)</b>	

# 1. INTRODUCTION

The efficient co-ordination of street works is one of the most important aspects of street works legislation, benefiting street authorities, undertakers and road users alike. The New Roads and Street Works Act 1991 (NRSWA) sets out the objectives of the co-ordination function:

- to ensure safety
- to minimise inconvenience to people using a street, including a specific reference to people with a disability
- to protect the structure of the street and the apparatus in it.

This Code of Practice is intended to help street authorities carry out their duty to co-ordinate works in the highway, under section 59 of NRSWA, and undertakers to fulfil their duty to co-operate in this process, under section 60 of NRSWA.

The legislative and regulatory provisions explained in this Code may be best viewed as three pillars of co-ordination:

- **The Notice System.** Notices provide valuable information to aid the co-ordination process, while notice periods provide time for appropriate steps to be taken. See chapters 3-4, 7-8 and 10-11.
- **Streets subject to special controls.** Designation procedures allow for attention to be focussed on particularly sensitive streets. Traffic-sensitive streets are especially important in this context. See chapter 5.
- **The Co-ordination Tools.** The legislation provides tools to help the co-ordination process, including powers to restrict further works following substantial street or road works and to direct the timing, date and location of street works. See chapters 6 and 9.

Street authorities and undertakers must adhere to three key principles:

- the need to balance the potentially conflicting interests of road users and undertakers' customers
- the importance of co-operation and regular communication between street authorities and undertakers
- an acknowledgement that works programmes and practices may have to be adjusted to meet the statutory objectives of the co-ordination provisions.

This Code explains how these principles can be made to work in practice. Significant elements are:

- the fact that most notice periods specified in the legislation and regulations are minimum periods. Longer periods of notice should be given, and notice information should be updated, wherever possible
- the central role played by local liaison meetings between street authorities, undertakers and other interested parties
- the importance of the designation of streets subject to special controls. Street

authorities should confine designation to cases where it is strictly necessary. Undertakers must respect the objectives of designation when planning and carrying out works.

This Code applies to prospectively maintainable highways.

Everyone working in the highway should take account of the needs of all road users, including those with disabilities - whether they are pedestrians, equestrians, cyclists or drivers - at all stages in the planning and execution of works in the street. This has implications for the timing, method and scheduling of works. Inevitably, works in the street will interfere with road users and nearby residential and business premises to some extent. The aim should, however, be to avoid, where possible:

- serious traffic disruption
- works on recently resurfaced or reconstructed streets
- planned works within a short time of earlier works.

The provisions of this Code and its accompanying legislation cannot be achieved without the commitment of all concerned. Everyone should ensure that the information given is up-to-date, timely and correct, including a nationally consistent street gazetteer (NSG), Additional Street Data (ASD), and that all notices are given in accordance with the protocols contained in the Technical Specification for ETON.

As well as the powers contained in NRSWA and the Traffic Management Act 2004 (TMA), the street authority has further powers through other legislation such as the Highways Act 1980 and the Road Traffic Regulation Act 1984. It may also have powers granted by Local Acts.

### **Legislative framework**

The two most important elements in street works legislation are:

- (a) the duty of street authorities to coordinate all works in the highway (section 59 of NRSWA); and,
- (b) the duty of undertakers to co-operate in this process (section 60 of NRSWA).

It is essential that both street authorities and undertakers take these responsibilities seriously. This Code is intended to help them do so along with other statutory obligations.

Section 49 of NRSWA defines the term 'street authority'. On publicly maintainable highways, the street authority is the highway authority and usually this will be the relevant local authority. However, some highways are the responsibility of others.

The Welsh Ministers are the highway authority for the motorway and trunk road network, which is managed on their behalf by Transport Wales, to whom notices should be sent. Network Rail is the street authority for highways between the level crossing barriers, and there are others. All of these distinctions must be logged appropriately in the Register. See chapters 3 and 4.

### **Other statutory obligations**

Both street authorities and statutory undertakers operate under other statutes which

impose additional obligations that impact on those under NRSWA - for street authorities to co-ordinate all works, and for undertakers to co-operate.

Local authorities should act reasonably at all times and have duties imposed under a number of Acts.

Besides those duties under section 59 of NRSWA, a local traffic authority has an obligation to fulfil the Network Management Duty (NMD), under Part 2 of the TMA - to do all that is reasonably practicable to manage its road network effectively with a view to keeping traffic moving. Authorities need to have regard for the *Network Management Duty Guidance*<sup>1</sup>.

The NMD requires local traffic authorities, usually the local highway authorities, to manage their road network to achieve - as far as may be reasonably practicable having regard to their other obligations, policies and objectives - the following objectives:

- (a) securing the expeditious movement of traffic on the authority's road network; and,
- (b) facilitating the expeditious movement of traffic on road networks for which another authority is the traffic authority.

This may involve the exercise of any power to regulate, or co-ordinate, the use of any road, or part of road, in the road network (whether or not the power was conferred on them in their capacity as a traffic authority).

Under the NMD, local traffic authorities must establish processes, as far as reasonably practicable, to ensure that they:

- (a) identify causes, or potential causes, of road congestion or other disruption to the movement of traffic on their road network; and,
- (b) consider any possible action that could be taken in response or in anticipation of such causes.

The processes should cover a wide range of activities, such as, identifying and managing different roads or classes of roads, monitoring the road network, and the co-ordination and direction of works - which includes the management of an authority's own works for road purposes to minimise its impact on all road users.

However, there is no requirement to identify or consider anything that appears to have only an insignificant effect (or potential effect) on the movement of traffic.

Under the TMA, the Welsh Ministers have the power to intervene in a local traffic authority, if they consider that a local traffic authority may be or is failing to perform any of its network management duties, through the use of an 'Intervention Notice' or 'Intervention Order' respectively. A guidance document, *The Traffic Management (Guidance on Intervention Criteria) (Wales) Order 2007* has been published by the Welsh Ministers<sup>2</sup>. It sets out what the Welsh Ministers would take into account in determining whether or not a local traffic authority is performing its network management duties. This includes:

- (a) co-ordinating and planning works and known events; and,

---

<sup>1</sup> *Traffic Management Act 2004 Network Management Duty Guidance* available at <http://new.wales.gov.uk/topics/transport/publications/DutyGuide/?lang=en>

<sup>2</sup> *The Traffic Management (Guidance on Intervention Criteria) (Wales) Order 2007* SI 2007 No.1712 (W149)

- (b) ensuring parity with others, by applying the same standards and approaches to an authority's own works as to those of other works promoters.

There are additional duties on local authorities, for instance Part III of the Disability Discrimination Act 1995 (DDA), amended by the DDA 2005, gives disabled people a right of access to goods, facilities, services and premises. By providing integrated and accessible transport and a barrier-free pedestrian environment, local traffic and highway authorities will help deliver this right and fulfil their obligations.

The highway network is a valuable public asset and highway authorities want to protect its integrity. For example, the network managed by the Highways Agency, represents less than five per cent of the road network in England, and is valued at more than £80 billion (Source: Highways Agency 2005-06 accounts). The road network of local highway authorities often represents their most valuable and largest asset.

However, these local authority duties must be balanced against the statutory obligations of statutory undertakers. Statutory undertakers, or those in possession of a street works licence (under section 50 of NRSWA), have a legal right to carry out street works. Statutory undertakers are generally those companies that supply water, gas, electricity and telecommunications or control sewerage.

The utility companies have statutory obligations to provide a supply or service, and these are closely monitored by the utility regulators, OFWAT (water industry), and OFGEM (gas and electricity industries) to ensure that the required level of service is maintained. This will include restoring supply, as well as ensuring new customers are connected within certain time frames. OFCOM (regulator of telecommunications) places a universal service obligation on BT across the UK (except Hull, where it is Kingston Communications), to meet all reasonable requests for service. Under legislation customers of the electricity, gas or water companies, subject to certain exemptions, may be entitled to compensation, if a company fails to meet these guaranteed standards of performance<sup>3</sup>.

The operators of a gas network also have obligations under Regulations enforced by the Health and Safety Executive<sup>4</sup>. These require operators of gas networks to carry out certain works within a specific time or to replace certain types of apparatus within a specified period. Currently, the gas industry has a programme to replace all iron mains within 30 metres of properties, over 30 years, from 2001, with highest priority given to that apparatus at greatest risk, based on an agreed safety case to assess priorities. The priorities may change to reflect an escalation of risk based on either new information about specific types of pipes or apparatus, or as result of incidents involving a specific pipe.

---

<sup>3</sup> *The Electricity (Standards of Performance) Regulations 2001* (as amended), the *Gas (Standards of Performance) Regulations 2005* (as amended) and the *Water Supply and Sewerage Services (Customer Service Standards) Regulations 1989* (as amended).

<sup>4</sup> *Gas Safety (Installation and Use) Regulations 1998 SI 2451* and *Gas Safety (Management) Regulations 1996 SI 551*

**This Code of Practice should be read in conjunction with the Technical Specification for Electronic Transfer of Notices (EToN)**

The NRSWA, the TMA and other relevant regulations must be consulted in conjunction with this Code. As should the other Codes of Practice published under the NRSWA: *the Network Management Duty Guidance* and the *Guidance on Intervention Criteria*, published under the TMA.

Transport Wales

January 2008

## **2. CO-ORDINATION IN PRACTICE**

### **2.1 Introduction**

This chapter sets out the statutory basis for co-ordinating works in the street.

Section 59(1) of NRSWA requires street authorities to "*use their best endeavours to co-ordinate the execution of works of all kinds (including works for road purposes and the carrying out of relevant activities) in streets for which they are responsible:*

- (a) in the interests of safety*
- (b) to minimise the inconvenience to persons using the street (having regard, in particular, to the needs of people with a disability)*
- (c) to protect the structure of the street and the integrity of apparatus in it."*

This duty includes co-ordination with other street authorities if works in one street affects streets for which another authority is responsible. Where appropriate, this includes street managers.

The duty has been extended through the Network Management Duty, which requires a more pro-active approach to the management of the road network and the way authorities should tackle the causes of congestion and disruption.

Section 60 of NRSWA places a duty on undertakers to use their best endeavours, with regard to the execution of street works, to co-operate with the street authority and one another, with the same threefold objectives as mentioned above.

These sections form the basis of this Code of Practice and impose a statutory obligation on street authorities and undertakers to have regard for it in the steps they take to co-ordinate works.

#### **2.1.1 The objective**

Co-ordination enables differences between those competing for space or time in the street, including traffic, to be resolved in a positive and constructive way.

Street works reduce the width of the street available to traffic, pedestrians and other users. The level of disruption caused by restricting movements will depend on the type of works and how busy the street is. An objective method to calculate disruption is described in 12.7 and Appendix G.

Works where the traffic flow is close to, or exceeds, the physical capacity of the street will cause serious disruption, although works in any busy street will cause some disruption. Small scale works in a non-traffic sensitive street may only cause minimal disruption to residents and delivery vehicles, although this could still be an issue for residents. However, a cluster of small scale works close to a much larger scale one could cause serious disruption. Effective co-ordination therefore needs to take into account proposals of every scale and duration.

Effective co-ordination is essential to minimise traffic disruption whilst allowing promoters the necessary time and space to complete their works. The disruptive effect of any one

proposal should not be considered in isolation. The combined effect of all the activities taking place on a road network will impact on the traffic.

### **2.1.2 The process**

The co-ordination process has four phases:

- |                    |  |
|--------------------|--|
| (a) Information:   | The street authority needs accurate and timely information on what is proposed and when it is happening                      |
| (b) Analysis:      | The street authority needs a means of assimilating and analysing this information  |
| (c) Consideration: | The street authority must consider whether any changes are required to minimise disruption before it agrees to the proposals |
| (d) Co-operation:  | All parties must co-operate with the street authority to achieve the minimum disruption.                                     |

## **2.2 Information**

NRSWA places significant obligations on both undertakers and local authorities to register works although the requirement to give notice of certain works applies only to undertakers.

### **2.2.1 Notices**

Successful co-ordination requires accurate and timely information, along with good communication between street authorities and undertakers. The street authority cannot fulfil its duty, under section 59 of NRSWA, to co-ordinate activities affecting the street without adequate advance notice of proposed works.

Although NRSWA applies only to undertakers proposing street works, highway authorities proposing road works should follow the same principles. Chapter 8 explains how notices should be given and the notice period required

The basic principle of minimum notice periods is: the greater the disruption, the longer the notice period required

Undertakers should recognise that statutory notice periods are the minimum, and whenever possible, longer periods should be given. This benefits both the street authority and the undertaker - if modifications are required, the earlier the street authority informs the undertaker, the easier it will be for them to comply. There may be circumstances where the street authority and others concerned have no objection (or indeed, find it advantageous) to an undertaker proceeding before the end of the full prescribed notice period. In such cases, consent should be given to an early start. See 8.3.9

A street authority can request early warning of immediate works on streets that it has designated on the ASD as vulnerable to traffic disruption. In these cases, the promoter should ring the authority's specified number as soon as works become necessary or, at the latest, as soon as they begin.

Undertakers should be prepared to discuss their proposals with other interested parties, including frontagers, and to modify them if it is appropriate and practical to do so.



## 2.2.2 Co-ordination machinery

In some cases the street authority and works promoters will be able to co-ordinate effectively on a one-to-one basis. However, for the most part, regular meetings of dedicated groups will be needed and the Regional HAUCs and local co-ordination meetings provide the means to do this.

The key principles of effective co-ordination are:

- sharing of information and consultation between interested parties at earliest opportunity
- regular input and attendance of relevant people (those empowered to take decisions) at co-ordination meetings
- works promoters and authorities sharing business development plans, and replacement programmes for apparatus and highway assets with co-ordinating authority
- communication of decisions at the earliest opportunity so that promoters plans can be adapted, if necessary
- cross-boundary co-ordination between neighbouring authorities, utilities, and others, especially for all planned works and planned maintenance on strategic routes.

### Regional HAUCs

At a regional level, the groups should be set up under the aegis of regional Highway Authorities & Utilities Committees (HAUCs). Principal issues will be policy determination within national HAUC guidelines; monitoring the effectiveness of local co-ordination arrangements; and providing policy guidance on a local basis. They should also facilitate local dispute resolution procedures. If the parties wish, performance reviews could also be carried out at these meetings.

### Local co-ordination

At a local level, these groups should be organised and chaired by the Traffic Manager (or the nominated deputy) of the relevant street authority. They may be convened at an area level (e.g. County level) if appropriate, but wherever possible, the groups should be based on a highway authority's managed area and include other relevant street authorities. The meetings will be concerned primarily with direct co-ordination of individual schemes and dissemination of information.

Local groups should meet quarterly or more frequently if the need arises, but a discussion should always take place whenever proposed major works are likely to conflict with other activities, especially in a street or streets known to be prone to congestion. They should cover:

- specific major works with, wherever possible, fully-costed and assessed alternative routes for works proposals and a full assessment of the preferred route
- medium-term and annual works programmes for all works promoters, submitted at least 21 days before the meeting, and showing a six month rolling programme of

work. This will allow the local authority to compile a co-ordinated schedule of works.

- planned road closures for the next quarter and rolling year ahead, to allow all street and road works to be planned within such closures as far as possible.
- other significant events.

The following topics may also be covered, if they do not conflict with the main aim of the meeting:

- local policies and strategies affecting street works, traffic management proposals (including the effect of diversionary routes), and the potential for reducing disruption from works through common schemes/trench sharing etc
- proposed designations of streets subject to special controls and other constraints
- reviews of performance at local level, including damage prevention
- feedback from HAUC(UK)
- street works licences
- any joint forward advertisement of street and road works where major traffic disruption is likely.

Representatives from all major interests would include undertakers and other promoters, and the Highways Agency if there are motorways or trunk roads within the area.

### **Liaison with other bodies**

Street authorities should liaise with adjacent street authorities if works are likely to affect traffic flows across boundaries and/or trunk roads. They should also provide information to other bodies likely to have an interest such as:

- the police, fire, ambulance and other emergency services
- public transport operators
- any other appropriate bodies, e.g. organisations representing disabled people, pedestrians, motorists, and cyclists
- the appropriate planning and environmental health officers.

## **2.3 Analysis**

Local co-ordination meetings are valuable for sharing information and enabling all parties to understand each others' difficulties and constraints. But they cannot be in permanent session and realistically they can only cover major programmes and proposals with relatively long lead times.

The day-to-day co-ordination of the majority of proposals can only be achieved through the use of technology, especially given the relatively short lead times for minor and standard works.

Two significant changes have been introduced in the notice regulations. These have been made in line with this edition of the Code:

- it is now mandatory that street works notices include National Grid References (NGRs)
- the nationally consistent street gazetteer has been enhanced to Level 3<sup>5</sup>.

To make best use of modern technology, street authorities will need notice management systems that use GIS. This will enable them to view all proposals and current activities against a map background. Potential problems will be evident, allowing appropriate action to be taken.

To increase the benefit of these changes, street authorities should request that NGRs are also given on other relevant documents, such as applications for skips or scaffolding on the highway.

## 2.4 Consideration

Street authorities must consider all aspects of the proposed works and other influences that may affect traffic, which include:

- the road network capacity
- the scope for collaborative working arrangements, including trench and duct sharing, between undertakers and the street authority
- the optimum timing of works from all aspects
- the effect on traffic; in particular the need for temporary traffic restrictions or prohibitions
- appropriate techniques and arrangements particularly at difficult road junctions and pinch points
- the working arrangements required in protected and traffic sensitive streets, and streets with special engineering difficulties
- the effect of skip and scaffold licences, any known special events and other licences or consents issued in respect of affected streets under the Highways Act 1980
- developments for which planning permission has been granted on streets affected by the works.

## 2.5 Co-operation

The primary aim of section 59 is for the street authority to co-ordinate works in the street with the active co-operation of all parties concerned.

Undertakers proposing works in the street have a statutory duty to co-operate with the street authority under section 60 of NRSWA. In addition, under section 68 undertakers must provide street authorities with the facilities to ascertain compliance. Failure to comply with section 60 or section 68 may constitute a criminal offence.

A street authority should discuss any difficulties that the proposed works cause with the promoter and agree an acceptable way forward. However, safety concerns, urgency or lack of co-operation, may make it necessary for the street authority to use its powers of

---

<sup>5</sup> *Spatial datasets for geographical referencing - Part 1: Specification for a street gazetteer BS7666-1:2006*

direction. These are covered in chapters 6 (Restrictions) and 9 (Directions).

## **2.6 Forward Planning**

### **2.6.1 Forward planning information**

Forward planning information on long-term programmes from all works promoters will help highway authorities to co-ordinate works. It will also help works promoters to identify opportunities for joint working and to co-ordinate the timing of resurfacing. This might include mains replacement programmes or reconstruction of main roads, which will be planned several years ahead.

Works promoters should give such information about road or street works in their long-term programme, which may include those works in their annual operating programme, or three or five year rolling programmes. This forward planning information could also include works identified through asset condition surveys. It could be provided at any time before the advance notice under section 54 is required.

It is much easier to adjust the timing of medium and long-term programmes to fit with the plans of other works promoters than to do so when the detailed plans are available and contractual commitments may have been made. While accurate information is important, it is accepted that the longer the lead time the greater the uncertainty about timing.

### **2.6.2 Recording information.**

It is essential that information on large scale or potentially very disruptive works and activities, is included in the street works register at the earliest opportunity (in either a separate section or flagged as forward planning). This will enable works promoters to:

- take part in early co-ordination
- consider joint working
- consider trench sharing
- highlight other works which need to be co-ordinated with these works
- produce reports for works co-ordinators.

The entry should give as much detail as possible. The minimum information needed is the street involved, the nature of the works and the proposed dates - which may be just a calendar year. This information should be reviewed and updated regularly to include details as they are finalised. Forward planning information does not remove the need to provide a notice under section 54 or section 55 at the appropriate time.

### **2.6.3 Entering information into the register**

It is the street authority's responsibility to enter forward planning information into the relevant section of the street works register. This will be made available alongside other information in the register.

An EToN message type has been developed for sending forward planning information - this can be found in the Technical Specification for EToN.

Alternatively, promoters can send forward planning information about works electronically

using the format in Table 2 below. Information should be provided in the order shown. The highway authority may need to reorder data before converting it into a CSV file for entry into the register. The six-digit grid reference number is important for providing reasonably accurate information on location of works.

<b>Table 2.1: Spreadsheet contents for forward planning information about works on the highway</b>	
	Guidance notes. (Do not include guidance notes in spreadsheet)
Street authority	
Operational district	
Works promoter	
Date of last update	If applicable
Works promoters reference	If applicable
Town	
Locality	
USRN	
Street name	
Road number*	Road classification number
Grid reference (Easting)	Approximately the centre point of the proposed works
Grid reference (Northing)	Approximately the centre point of the proposed works
Works promoter contact name	Name of person who can answer queries regarding the works.
Works promoter contact number	Telephone number of above
Works description	
Works position	When known. Carriageway = C. Footway = F. Verge = V.
Traffic management type	When known
Length of works	When known
Width of works	When known
Start date of works	This may be just a financial or calendar year
End date of works	This may be just a financial or calendar year
Notes	
*Road classification provides works co-ordinators with information on a route basis.	

## 2.7 Collaborative Working

It is important that all street authorities and undertakers seek every opportunity possible to co-ordinate street and road works, as it can minimise traffic disruption and benefit the travelling public and the undertaker's customers. Such an approach cannot be imposed so the emphasis must be on mutual co-operation. To make such schemes work, promoters should speak to street authorities as early into the planning process as possible.

It should be possible to arrange contracts so that the excavating primary promoter serves

notice and carries out work on behalf of itself and others. However, it must be emphasised that such arrangements do not remove the legal liability imposed by NRSWA on individual undertakers.

## **2.8 Reinstatements**

Reinstatement cannot always be completed in one site visit; although undertakers are encouraged to use first time permanent reinstatements wherever possible. The first phase of works may be completed to only interim reinstatement standard and a second phase will be needed to complete the work to permanent reinstatement standard.

A further set of notices is required to complete works from interim to permanent reinstatement stage. This must start with a new section 55 notice of proposed start date, using the same works reference as the first phase of works. This ensures continuity of notices through the whole life cycle of the works. See sections 8.2.11 and 8.2.12

Remedial, non-dangerous reinstatements should be notified as new works, using the remedial works category and use the promoter's original works reference number, and follow the normal noticing rules for major, standard or minor works, as shown in Table 5 at 7.5.1. However, if for any reason the original works reference number cannot be used, then a new number should be allocated and provide a cross-reference to the earlier works. This is set out in the Technical Specification for ETON.

## **2.9 Phasing of Works**

All works must be carried out as quickly as is reasonable with the minimum disruption to other street users. Wherever possible they should be completed in a single occupation of the street to permanent reinstatement.

If this cannot be done, the works to complete the reinstatement from interim to permanent are regarded as two separate phases, although the same works reference number is used. Under the provisions of NRSWA this will mean separate works notices and durations for the purposes of section 74.

The first works are from the start date in the first notice until the completion of interim reinstatement and the removal of all surplus materials and equipment, etc from site.

The second works are from the start date in the second notice until the completion of permanent reinstatement and the removal of all surplus materials and equipment, etc from site. The same works reference should be used for all phases.

Undertakers must discuss any works requiring more than two phases with the authority. All notices shall include a phase type. See the Technical Specification for ETON.

### **2.9.1 Immediate works**

Immediate works may need to be followed by further works, for example, to renew an asset following a temporary repair and reinstatement of the highway. In these instances, subsequent works should be treated as separate works for noticing purposes - using the same works promoter reference but a different works category.

If the reinstatement of the carriageway was interim, and subsequent works are carried out

before that reinstatement is made permanent, it will be necessary to use the same works reference number. The notice should state that the permanent reinstatement will be completed as part of these subsequent works.

Interim reinstatements must be made permanent within the timescales required. The anticipation of subsequent works is no reason to delay permanent reinstatement.

A diagram illustrating the phasing of works can be found in the Technical Specification for EToN.

## **2.10 Interrupted Works**

If works are interrupted because, for instance, the undertaker finds that he needs some specialist plant or apparatus, other than that originally planned for; it is the undertaker's responsibility to notify the authority of a revised estimated end date.

If works are interrupted because the undertaker, or his contractor, has caused third party damage, then it is the undertaker's responsibility to notify the authority of a revised estimated end date, taking into account the likely duration of the repair works. The works remain the responsibility of the original undertaker until it is able to issue a Works Clear or Works Closed notice.

If an undertaker's works are interrupted at the request of the street authority, they should discuss this and revise the estimated duration of the works.

Whenever works are interrupted, the undertaker should first agree a way forward with the street authority before starting any of the processes above.

## **2.11 Key performance indicators (KPIs)**

The Network Management Duty requires every local traffic authority to assess its performance in managing its road network and review the effectiveness of its arrangements.

Parity is an important principle in exercising the duty. Authorities must lead by example, applying the same standards and approaches to their own activities as to those of others, such as utility companies and developers. Authorities are required by regulations under section 53 of NRSWA to place information about their own works on the street works register in the same timescales as undertakers. It is recommended that the same processes and systems are used to achieve this. These can then be used to demonstrate parity.

KPIs are being developed using information available via the existing notice management systems. Following this Code will mean data registered against all types of works will be consistent. The data structures defined in the Code support the development of the KPIs, although additional information may have to be recorded against some activities.

KPIs should encourage a culture of continuous improvement for all works promoters working in the highway. KPIs will allow regional HAUCs to recognise those local authorities and works promoters that are not improving, and to work with them to identify the causes and agree mitigating actions.

Authorities may publish KPIs on their websites. This will help demonstrate performance of the network management duty.



## **3. THE REGISTER**

### **3.1 Introduction**

The Register provides a single source of information on on-going, or planned works by undertakers and highway authorities, alongside a list of all streets in an authority's area, whether or not it is the street authority, and associated data for each street, where relevant, that may include whether it has been designated (see chapter 5) or is subject to a restriction on works (see chapter 6).

Notice management systems receive street works notices electronically and allow an authority to manage them together with other relevant information. It often happens that one computer system doubles-up as the register and the notice management system in a street authority. This is acceptable provided that the system fully meets the requirements for both Registers and Notice Management Systems.

### **3.2 Register keepers**

Under section 53 of NRSWA each street authority is required to maintain a register for every street for which they are responsible. The register should contain information about street works and other prescribed types of works.

For maintainable highways, the street authority is the highway authority.

For streets which are not maintainable highways (non-publicly maintainable or private streets) the street authority is the street managers. This might impose unreasonable burdens on street managers, who are often just the householders fronting the street, so the regulations exempt street managers from the requirement to keep registers. Instead, the local highway authority is required to keep the register in respect of non-maintainable highways.

### **3.3 Local and Central Registers**

A local register is a register that is maintained by a single street authority for its own geographic area. It will include information on all streets other than those that are the responsibility of another street authority.

A central register is a register covering two or more street authority areas that is maintained by one single authority, the 'register authority'. A central register could, for example, include all authorities in a metropolitan area.

### **3.4 Form of Registers**

The register shall be kept on an electronic system. The Regulations require that all registers shall be based on GIS by 1 April 2009. Each register must be maintained against the same digital map base to ensure consistency between all holdings of street-related data. This common geographical dataset should be vector-based, nationally consistent, maintained, and seamless with changes published on a regular update cycle.

It should include:

- vector objects (polygons, lines and points) representing real-world geographical features and boundaries, each with well-defined lifecycles and royalty-free unique identifiers suitable for referencing
- road centreline geometry objects, each with royalty-free unique identifiers, which reference the road surface and form a complete and fully consistent topological network, with no breaks or misalignments at administrative boundaries.

Authorities should synchronise their holdings of the common digital map data so that they all contain the same version at any given point in time.

<b>Table 3.1: The minimum specification of the common map base</b>	
Scale	Urban areas: 1:1250 Rural areas: 1:2500 Remote areas: 1:10000
Accuracy	Urban areas: ± 1.0m Rural areas: ± 2.0m Remote areas: ± 4.0m
Coverage	National and seamless, exhausting space over all land areas.
Geometry types	Point, line and polygon.
Classification	Objects classified by physical form.
Update cycle	8 weeks max.

All streets in Local Street Gazetteers should reference the road centreline geometries in the common map base (using royalty-free unique identifiers), which should in turn reference polygons representing the road surface. Such a structure promotes consistency and maximises the possibility for interoperability between applications, both in the highways arena and in a wider context.

In essence, local authorities should provide the USRN definitions and attribution as defined in BS7666: 2006 Part 1, while the geometries should be recorded by referencing the road centreline objects in the digital map base. This will promote reuse and consistency between datasets. All data should follow the principles of the Digital National Framework ([www.dnf.org](http://www.dnf.org)).

## **3.5 Content of Registers**

3.5.1 The register must record:

- particulars of all notices, under sections 54, 55 and 57, served on the highway authority relating to street works in any street which is a maintainable highway
- particulars of all notices, given under sections 54, 55 and 57, served on street managers relating to street works in any street which is not a maintainable highway
- particulars of all directions given under section 56 or 56A
- particulars of all notices, consents and directions published or given by a street authority under section 58 or 58A
- particulars of all notices served by an undertaker under section 58A

- particulars of all notices served by a street authority under section 66
- particulars of all notices given by a street authority under section 72(3)
- particulars of all notices given under section 74.
- description and location of street works for which plans and sections have been submitted under Schedule 4 to NRSWA (streets with special engineering difficulties)
- particulars of all notices given by any relevant authority under Schedule 4 to NRSWA
- details of every street for which the local highway authority is the street authority
- details of every street which is a prospectively maintainable highway
- details of every street, of which the local highway authority is aware, which is a highway, but for which it is not the street authority
- details of every street, or part of street, which is: a) a protected street; b) a street with special engineering difficulties, or, c) a traffic-sensitive street and proposed designations
- description, timing and location of both street authority works for road purposes and any such works that are proposed
- particulars of all consents under section 61, along with any conditions
- details of all directions under section 62
- particulars of street works licences, including details of conditions and changes of ownership
- information under section 70(3) and (4A) as to completion of reinstatements
- particulars of apparatus notified to the street authority under section 80(2)
- every notice of works under section 85(2)
- details of road closures and diversions, where an order under section 14 of the Road Traffic Regulation Act 1984 is required
- the road category of each street.

### **3.5.2 Registerable and notifiable works**

There is a difference between registerable works and notifiable works, although this is not significant in practice. These are identified through notices given in respect of street works ('notifiable works') and registrations of works for road purposes by the street or highway authority ('registerable works'). The requirements for registerable works and notifiable works are set out in Chapter 7.

## **3.6 Access to Registered Information**

### **3.6.1 Access to registers**

Everyone has a right to inspect the register, free of charge, at all reasonable times, except as noted in 3.6.2. "All reasonable times" may be taken to mean normal office hours (08:00 to 16:30, Monday to Friday except Bank Holidays).

Street authorities are strongly recommended to publish the register on their public website. This should be available 24 hours a day, seven days a week, except for those occasional times when it will be unavailable due to upgrade and maintenance. This work should, wherever possible, be done outside normal office hours.

Much of the detailed information in the register is unlikely to be of interest to the public. It is therefore suggested that the website display headline information first and allow users to drill down to more detailed information. However, it is the responsibility of the local authority to decide which information to make available in this way.

Notices contain confidential information such as names and telephone numbers of contacts in organisations. Authorities should make sure that such information, as described in paragraph 3.6.2, remains confidential. Authorities should also make it clear that they are not responsible for the accuracy of information concerning those works for which they are not the promoter.

The website should allow records to be searched and retrieved by the USRN or the "street descriptor" (the street name, description or street number) as given in the NSG.

**Public access to websites should be read-only to prevent unauthorised amendment to records.**

### **3.6.2 Restricted information**

Restricted information is anything certified by the Secretary of State for Transport as a matter of national security, or, information, which could jeopardise the undertaker's commercial interests. If it were not restricted it might reveal, for example, information about a contract under negotiation. The undertaker should indicate restricted information on the notice.

Restrictions on the release of information should be as limited as possible. In particular, it should not be assumed that because one item of information about a works needs to be restricted, all information about it does. For example, an advance notice might need to be restricted for commercial reasons, whereas later notices need not be. The case for restriction needs to be considered on a notice-by-notice rather than a works-by-works basis.

The right of access to restricted information is limited to:

- (a) Persons authorised to execute any type of works in the street or
- (b) Persons "otherwise appearing to the authority to have a sufficient interest".

Any person wishing to see restricted information must satisfy the street authority, as a minimum, that his interest is greater than the general interest of the ordinary member of the public.

**Restricted information should not be shown on highway authorities' websites.**

### **3.6.3 Retention of information**

Information provided by means of any notice under NRSWA should be retained on the register for at least six years after completion of the guarantee period of the works referred to in the notice. Information about other works should be retained on the register for at least six years after completion.

Any legal claims in relation to the works must be brought within six years of the date on which the event, which forms the basis of the claim, occurred. In the case of personal injuries, claims must be brought within three years of the date on which the event happened. However, in the case of a person who is below 18 years of age, the claim can be made up to three years after they reach 18. Information should be kept for those periods for that purpose; which may mean 21 years and nine months in the case of injury to an unborn child.

Street authorities will need to decide how to keep the information on the register. Because of the size of the database the authority may decide to archive information, or a subset of the information on the register for a longer period or even indefinitely.

**Both authorities and utility companies will need to obtain their own legal advice and guidance on how to meet these requirements.**

## **4. THE STREET GAZETTEER AND ADDITIONAL STREET DATA**

### **4.1 Introduction**

This chapter provides information about a nationally consistent street gazetteer (“NSG”), which contains basic and consistent information about all streets in Wales.

### **4.2 The Street Gazetteer**

Every local highway authority produces a Local Street Gazetteer (LSG) and a validated copy is held centrally by the NSG Concessionaire. Each of these local gazetteers shall contain the information, required by and defined in the Technical Specification for EToN, about the streets in that authority’s area.

Highway authorities and statutory undertakers can obtain full copies and updates of the street data from the NSG Concessionaire’s website, [www.thensg.org.uk](http://www.thensg.org.uk).

#### **4.2.1 Creating and updating the NSG**

Street gazetteers shall be created, maintained and published at Level 3 (as defined in BS 7666).

It is the local highway authority’s responsibility to create and maintain street gazetteer data for all streets within its geographical area, whether or not it is the street authority for any particular street.

#### **4.2.2 Referencing**

Information held in street works registers, and notifications concerning street works given under this Code of Practice, must be referenced to the Unique Street Reference Number (USRN) which relates to the Type 1 or Type 2 street entry (see the Technical Specification for EToN) given in the street gazetteer for each street.

It is essential that all users are working from the same data. The NSG custodian holds validated local street gazetteer data, which the LSG custodian (street authority) should download and use.

#### **4.2.3 Provisional streets**

A provisional street is a street that does not yet have an entry in the NSG. Typically, these will be new and/or private streets. The street authority must register private streets. The proposed works should be notified against a provisional street only if a works promoter is certain that a street is not in the NSG. It is then the responsibility of the local highway authority to allocate a USRN, notify the works promoter, and create an entry in the LSG and the NSG website. The promoter should then use the new USRN in all further notifications relating to the works.

Under section 87 of NRSWA, a highway authority should make a declaration that a street is likely to become a maintainable highway. The declaration should be registered as a local land charge.

### **4.3 Additional Street Data**

Additional Street Data (“ASD”) refers to other information about streets held in the register that is available from the NSG Concessionaire’s website alongside the NSG data. Highway authorities, statutory undertakers, and other interested and approved parties, can obtain copies and updates to this data from the concessionaire.

Local highway authorities must provide the following information:

- (a) the street authority responsible for maintaining the street
- (b) whether the street is publicly maintainable, prospectively publicly maintainable, or private
- (c) any other authorities with an interest in the street
- (d) the street reinstatement category
- (e) designations of protected streets
- (f) designations of streets with special engineering difficulty
- (g) designations of traffic-sensitive streets
- (h) where possible, streets on which it might be expected that section 56A directions may be used
- (i) other features of the street, such as structures, environmental areas, parking restrictions, priority lanes, special surfaces, standard surface and special construction needs etc.

Items (a) to (g) are mandatory and (h) and (i) are optional, although street authorities are urged to make full use of this facility.

If all parties agree, the ASD may also be required to contain other data that Transport Wales may need from local authorities - such as inventory data, traffic regulation and parking restriction orders that apply to the street and may need to be lifted temporarily for works.

#### **4.3.1 Responsibility for creating and updating**

Where the street authority is also the local highway authority, it creates the ASD together with the NSG.

Where the street authority is not the local highway authority, the street authority may create and submit its own ASD to the NSG Concessionaire, referenced to the local highway authorities’ gazetteers. Organisations that fall into this category are:

- Network Rail.

Any other authority, works promoter or interested party should submit records to the NSG Concessionaire to ensure that its interest in a street is logged. The interest records should be entered into the ASD maintained by the local highway authority. This is particularly

appropriate to neighbouring authorities in the exercise of their network management duties. The NSG Concessionaire will administer this process.

#### **4.3.2 Procedures for creating and updating**

The relevant authority should forward additions or amendments to the ASD to the NSG Concessionaire - using the formats in the Technical Specification for EToN. These become valid as specified in the regulations.

It is essential that users work from the same data, especially in the case of designations, but it is impractical to require users to download updates from the website daily until dynamic on-line updating is available. It is now proposed that updates are made on a monthly basis, so that any changes to the ASD will be as current as possible without the requirement for on-line updating. Users of the ASD data must ensure that they are using the most current version of the data.

Provision for dynamic on-line updating of ASD is expected in the future.



## **5. STREETS SUBJECT TO SPECIAL CONTROLS**

### **5.1 Introduction**

The notice and co-ordination system balances the need to reduce the bureaucracy involved in managing street works with the importance of minimising delay and inconvenience to road users, whilst protecting the integrity of the street and any apparatus in it. To achieve this NRSWA provides for three categories of streets to be subject to special controls:

- protected streets
- streets with special engineering difficulties
- traffic-sensitive streets.

### **5.2 Protected Streets**

#### **5.2.1 Background**

By virtue of section 61 of NRSWA, all “special roads”, as defined in the Highways Act 1980 (i.e. motorways), are protected streets. In addition, a street authority may designate other protected streets that meet criteria specified in the regulations.

#### **5.2.2 Designation**

Streets may be designated as protected, only if they serve, or will serve, a specific strategic traffic need, with high and constant traffic flows, and there is a reasonable alternative route in which undertakers can place the equipment, which would otherwise lawfully have been placed in the protected street. This includes services to existing or proposed properties in the street, or trunk supply routes passing through the street.

#### **5.2.3 The implications of designation**

Once a street has been designated as protected, the activities of undertakers and highway authorities will be severely restricted.

Undertaker’s apparatus may not be placed in the street (except by way of renewal) without the street authority’s consent, although, under NRSWA, lateral crossings should normally be allowed. However, if it is allowed with conditions attached, the street authority may contribute to the undertaker’s expenses in complying with those conditions. Any disputes that arise over designation of a protected street shall be settled by arbitration. See section 13.5 of this Code.

Undertakers’ works in verges and central reservations, which do not impinge on the carriageway, should usually be acceptable. Road maintenance or repairs will, in general, be carried out only at night, weekends, or other times with less impact on traffic.

However, working at night may cause conflict with Environmental Health Legislation. See section 12.8.

#### **5.2.4 Existing streets**

Given the possible financial implications for both highway authorities and undertakers, designation should be contemplated only when essential.

The decision should be taken only after consultation and after other means of reducing delay and inconvenience have been explored.

The street authority must justify the need and:

- (a) take account of the needs of utilities to supply and maintain services to frontagers and to use such streets for existing trunk supplies.
- (b) reimburse reasonable expenses incurred by the undertaker if removal or alteration of apparatus in the street is required (subject to appropriate allowances for betterment, deferment of renewal and value of recovered apparatus). The cost-sharing arrangements for diversionary works do not apply.

#### **5.2.5 New streets**

Where construction of a street is planned and it is being considered for designation, the street authority shall consult all undertakers and others, such as transport, bridge and sewer authorities, as well as adjacent landowners and frontagers, who might have an interest. Where requested and reasonably practicable, the highway authority will make provision, at the undertaker's expense, for necessary areas or strips for carrying services alongside carriageways, and for duct or service crossings.

### **5.3 Streets with Special Engineering Difficulties (SED)**

#### **5.3.1 Background**

Under section 63 of NRSWA, the term 'special engineering difficulties (SED)' relates to streets or parts of streets associated with structures, or streets of extraordinary construction, where works must be carefully planned and executed to avoid damage to, or failure of, the street itself or the associated structure, with attendant danger to person or property.

Under Schedule 4 to NRSWA, plans and sections of proposed street works must be approved by each authority with an interest in the structure concerned, i.e. the street authority, and/or the sewer, transport or bridge authority.

#### **5.3.2 Scope of designations**

The designation of streets with SED should be used only where strictly necessary, bearing in mind the safeguards already provided elsewhere in NRSWA, for example sections 69 (for other apparatus in the street), 88 and 89 (for bridges and sewers), and 93 (level crossings and tramways). This is in the interests of all concerned - street authority, undertaker, and where appropriate, the owner of the structure.

Circumstances where designation may be appropriate include:

#### **Bridges**

The street may be designated if the bridge authority is concerned about the impact of

street works on the strength, stability or waterproofing of the bridge, or access for maintenance or any other purpose. In general, the designation would relate to the whole of the bridge structure, but it will only be necessary to designate the area adjacent to the bridge and not the whole length of the street.

### **Retaining walls**

Retaining walls may be designated where they give support to the highway and bridge abutments, and where the foundations are sufficiently shallow for excavation to affect the integrity of the structure. Where foundations are piled, designation is likely to be necessary only if excavation could alter the degree of support given to the piles by the soil.

In many cases, it will be necessary to designate only the adjacent area and not the whole width of the street. A distinction should be made between areas appropriate for excavations no deeper than 1.2 metres, and areas where further restrictions are needed if an excavation is deeper.

### **Cuttings and embankments**

Areas adjacent to cuttings and embankments should be designated if excavation could lead to slides or slips of the soil, or could affect special construction features such as earth reinforcement systems or lightweight fills. The whole width of street, or specific areas similar to those for retaining walls, may be designated

### **Isolated structures**

Examples of isolated structures include high-mast lighting columns and large sign gantry supports. Where excavation could affect stability, areas immediately around the supports should be designated, again distinguishing between excavations up to 1.2 metres deep and those that are deeper.

### **Subways and tunnels at shallow depth**

Areas immediately above subways and tunnels and adjacent areas may be designated.

### **Tramway tracks in the street**

Areas occupied by the tracks and immediately adjacent areas may be designated. Additional protection to the appropriate authority is also given in section 93 of NRSWA. See also 12.3.

### **Culverts**

The area of the street immediately above a culvert may be designated where the structural integrity of the pipe or channel could be adversely affected by works. Therefore, a reinforced concrete pipe or box culvert would not justify designation, but a masonry or steel culvert could be considered if the depth of cover is shallow.

### **Undertaker's apparatus**

Designation may be required only in exceptional circumstances, such as electricity pylons adjacent to the carriageway, or the presence of critical operational apparatus, for example, communications or signalling cables for transport operators like Network Rail. In most cases, the safety and security of apparatus is adequately covered by sections 69 or 89 of

NRSWA.

## **Pipelines**

Some types of government and private sector oil or gas pipelines, and similar structures which traverse the street, may justify designation.

## **Engineering problems**

Streets may be designated if they pose extraordinary engineering problems in the event of excavation - for example, a road, which might have been constructed using a continuously reinforced concrete slab or geo-textiles and is founded on very poor soil, such as a peat bog.

### **5.3.3 Designation on request**

A street authority may be asked to designate a street as having special engineering difficulties by:

- a transport authority, on the grounds of the proximity of the street to one of its structures
- an undertaker having apparatus in the street.

The street authority must consider any request carefully. It may then make the designation, with or without modifications, or decide not to do so. The street authority should consider the arguments for and against the proposed designation carefully and should always act reasonably in coming to its decision.

If the street authority declines the requested designation, the transport authority or undertaker may appeal to the Welsh Ministers.

### **5.3.4 Practical considerations**

Designations should not be made as a matter of policy wherever there is a bridge or structure that is likely to be affected by street works. Each case should be considered on its merits. Street authorities and owners of structures should re-examine these designations periodically and withdraw any that are unnecessary in the light of other safeguards in NRSWA or other legislation.

### **5.3.5 Cellars**

It is not practical for the street authority to identify all cellars under footways and carriageways, and to decide whether they justify an SED designation.

Owners of cellars must notify the highway authority under section 180 of the Highways Act 1980, if they wish to carry out works. The highway authority will in turn notify interested undertakers before work begins.

Street authorities and undertakers wishing to carry out work in areas where they know, or might reasonably be expected to know, of the existence of cellars should notify the cellar owners or frontagers when they intend to carry out:

- excavations close to cellars, or

- extensive excavations which will impinge upon cellars.

### **5.3.6 Policy guidance**

The street authority is responsible for designating sections of streets with SED, maintaining a list of such designations, and creating the appropriate ASD record - subject of course to the provisos in 4.3.1. However, it is important that:

- the owner of the structure informs the street authority of its existence so that it can be considered for designation
- the key relationship to ensure that adequate precautions are taken, is that between an undertaker proposing street works and the owner of the structure.

For this mechanism to work effectively, it is essential that:

- the street authority, undertakers, bridge authorities and other owners of relevant structures consult and co-operate on the designation, and withdrawal of designation, of sections of streets with SED
- on receipt of formal notices covering sections of street with SED, the street authority ensures that the necessary actions are in hand
- arrangements for handling immediate works on sections of streets with SED are agreed between undertakers and the owners of structures
- there are early discussions between undertakers and the owners of the structures concerned in the cases of planned major works and provision of new supplies.

## **5.4 Traffic Sensitive Streets**

### **5.4.1 Background**

Under section 64 of NRSWA a street authority may designate certain streets (or parts of streets) as "traffic-sensitive" if they meet the criteria set out below, or by agreement with the majority of undertakers known to have apparatus in the street concerned.

This designation highlights that works in these situations are likely to be particularly disruptive to other road users, but it does not necessarily prevent occupation during traffic-sensitive times. Even if a street meets one of the criteria, it does not mean that a designation has to be made - each case should be dealt with on its merits.

Depending on circumstances, designation may apply to the carriageway only, or to a footway or pedestrian area only, to part of a length of street, and to certain times of day, days of the week, or days of the year.

Once a designation is made it applies to all works taking place in the street. Highway authorities and undertakers should not work in the carriageway of traffic-sensitive streets at sensitive times unless there is no alternative.

### **5.4.2 The criteria for designation**

To encourage works outside the traffic-sensitive period street authorities should not make a designation for any period longer than is strictly necessary.

One or more of the following criteria should apply before a street authority may designate a street as traffic-sensitive:

- (a) The street is one on which, at any time, the street authority estimates traffic flow to be greater than 500 vehicles per hour, per lane of carriageway, excluding bus or cycle lanes.
- (b) The street is a single carriageway two-way road, the carriageway of which, is less than 6.5 metres wide, having a total traffic flow in both directions of not less than 600 vehicles per hour.
- (c) The street falls within a congestion charges area.
- (d) Traffic flow contains more than 25% heavy commercial vehicles.
- (e) The street carries in both directions more than eight buses per hour.
- (f) The street is designated for pre-salting, by the street authority as part of its programme of winter maintenance.
- (g) The street is within 100 metres of a critical signalised junction, gyratory or roundabout system.
- (h) The street, or that part of a street that, has a pedestrian flow rate in both directions at any time, of at least 1,300 persons per hour, per metre width of footway.
- (i) The street is on a tourist route or within an area where international, national, or significant major local events take place.

## **5.5 Procedure for making designations**

Before making any designation, the street authority shall give a notice which:

- specifies a period, of not less than one month, when objections may be made; and,
- for designations of streets as traffic-sensitive, identifies the criteria that is met.

To:

- every undertaker known to the street authority to be working in its area, and every undertaker that has given the authority notice of its intention to start working in its area
- every other local authority for the street to which the proposed designation relates
  
- the chief officer of police, chief executive of fire and rescue authority, the chief executive of the National Health Service ambulance trust and other emergency services
- Transport Consortia in Wales and other transport authorities, such as light rail operators
- any person who has submitted a written request to be given notice of a proposed designation. This may include other street authorities eg Transport Wales or Network Rail.
- for the designation of streets as protected, the occupiers of properties fronting the street concerned

In addition, when it proposed to designate a street as protected, the occupiers of any property that fronts the street concerned should be given a copy too. The above list is not definitive and there may be other bodies that could be consulted before making a designation, for instance neighbouring authorities, local groups. Authorities may also wish to publish proposed designations in local newspapers.

In the case of traffic sensitive streets, the notice must identify the criteria that means the street merits designation and it would be sensible to include the rationale.

If the street authority does not receive any objections within the specified period, or if all objections have been withdrawn, the authority may make the designation.

If there are outstanding objections at the end of the consultation period, the street authority must give them careful consideration. In the case of a proposed designation of a street as protected, a local inquiry should be held and its report considered alongside the objections. It may then make the designation, with or without modifications, or decide not to do so. The street authority should carefully consider the arguments for and against the proposed designation and should act reasonably in coming to its decision.

When a designation is made, the highway authority shall notify the NSG Concessionaire. The designation will become valid as specified in 4.3.2

## **5.6 Procedure for withdrawing designations**

It is recommended that the street authority reviews its designations periodically.

Any person entitled to a notice under the designation procedure, or any other person the street authority considers to have sufficient interest, may make representations to the street authority to withdraw the designation. The street authority should carefully consider the arguments for and against the proposed withdrawal of designation and shall act reasonably in coming to its decision.

A street authority can withdraw a designation at any time, subject to the following provisions:

- (a) If the original designation was made at the request of a transport authority or undertaker, no withdrawal shall take place without prior consultation with them.
- (b) If the original designation was made following a direction by the Welsh Ministers, no withdrawal shall take place without their consent.

Where a withdrawal is made, the highway authority shall submit the relevant ASD to the NSG Concessionaire as soon as possible, or within one month. The withdrawal will become valid as set out in 4.3.2.

## **5.7 Other Features of the Street (Structures, Environmental Areas etc)**

### **5.7.2 Features**

Many features of a street can affect the planning and co-ordination of street works. These may be subject to restrictions imposed by legislation other than NRSWA. To enable best

practice, information about such features may be held as Additional Street Data in the NSG. Data capture codes have been defined for the following features:

### **Environmentally sensitive areas**

These include such areas as Sites of Special Scientific Interest and Ancient Monuments. The Special Designation Description indicates the type of sensitive area.

### **Structures** (not designated as being of Special Engineering Difficulty)

Work near various structures in the highway warrants extra care, even if the structures are not designated as being of Special Engineering Difficulty. The guidelines in appendix D should be followed. The Special Designation Description indicates the type of structure.

### **Special surfaces**

These include, but are not restricted to, such surfaces as porous asphalt, tactile and coloured surfaces. The Special Designation Description indicates the type of surface.

### **Pipelines**

Government and private sector oil or gas pipelines.

### **Priority lanes**

These include cycle routes and bus lanes. The Special Designation Description indicates the type of priority lane.

### **Level crossing precautionary areas**

The Special Designation Description indicates the extent of the Precautionary Area. When works are proposed within the Precautionary Area, extra safety measures required by the rail operator must be applied. See chapter 12 and Appendix C.

### **Special construction needs**

This description indicates the extent and type of special construction and could include such sites as geo-textile mats and areas where sulphate-resistant concrete is required.

### **Parking bays and restrictions**

The Special Designation Description indicates streets with parking meters, residents' parking bays, parking restrictions such as red routes and other permanent restrictions. This will alert works promoters to plan any necessary action such as applying to the local authority to have parking suspended.

### **Pedestrian crossings and traffic signals**

The Special Designation Description indicates streets which have signal-controlled pedestrian crossings and permanent traffic signals.

### **Speed limits**

The Special Designation Description indicates the speed limit appropriate to the street.



**Transport authority critical apparatus**

This is apparatus used, or owned, by a Transport Authority that is critical to the operations of the Transport Authority and if damaged or interrupted could disrupt or temporarily stop services; for instance damage to high voltage cables supplying power to a rail network would cause its closure and severe inconvenience to their passengers.

**Special events**

There may be streets where special events, either one-off events (a fun run) or regular events (eg annual street fairs or parades) take place. The highway authority may wish to highlight such events in additional street data so that works promoters can consider how to adjust the timing of planned works to avoid any occurring during the special event or in the period leading up to the event. This can be done through the use of Type 23 record.

## **6. RESTRICTIONS**

### **6.1 Introduction**

People believe that road works take place without any thought given to minimising disruption to residents and road users. All too often, it appears as if roads have been dug up repeatedly by different bodies with no apparent co-ordination, or within months of resurfacing.

To address this, provisions have been made in NRSWA to allow authorities to restrict works in all or part of a street following:

- Substantial Road Works (Section 58) and,
- Substantial Street Works (Section 58A)

Restrictions apply only to the length of the street on which such substantial road or street works have been carried out.

The street authority may decide not to exercise its powers under section 58 or section 58A.

### **6.2 Substantial Works - Definitions**

#### **6.2.1 Substantial Road Works**

Substantial Road Works are works for road purposes affecting any of the carriageway, footway, footpaths, cycle tracks or bridleways and include resurfacing, reconstruction, widening or alteration of the level of the street. It includes specialist non-skid surface dressing.

Substantial Road Works extend at least 30 metres continuously and:

- reduce the width of a footpath, footway, bridleway or cycle track by more than two-thirds or
- prohibit the use of the carriageway by vehicles or
- reduce the width of the carriageway by more than one-third.

#### **6.2.2 Substantial Street Works**

Substantial Street Works means Major Works as defined in 7.5.2.

### **6.3 Creating a Restriction**

#### **6.3.1. Creating a restriction under section 58**

A minimum of three months in advance of the works, a street authority wishing to impose a restriction following Substantial Road Works, should:

- (a) Publish a notice on the authority's web site, stating the extent and nature of the proposed works and the proposed start date.

(b) Copy it to:

- any sewer, transport or bridge authority with an interest in the street
- anyone who has given advance notice
- anyone with apparatus in the street
- anyone who has registered an interest in that street
- occupiers of premises which have a frontage onto the part of the highway to which the proposed restriction relates.

Under section 58(3) failure to do so does not affect the validity of the restriction imposed by the notice.

(c) Place a copy of the notice on the register.

(d) Place a copy on any central registers.

Copies of notices should be given electronically by EToN or by post, where appropriate. Authorities may also wish to publish proposed restrictions in local newspapers.

The undertaker must respond within 20 days under Regulation 9(3) with details of any works in their schedules of works, or of which they may be aware, at any time until the proposed end of the restriction period. To meet the original timescales for the substantial road works, the street authority may decide to allow these street works to be carried out in accordance with the early start procedure as set out in 8.3.9 or may issue directions under s56 to reflect the programme discussed and agreed with undertakers. If a number of works are to be completed before the substantial road works take place the road works may be delayed and consequently the start date of the restriction. It would be helpful, if undertakers were informed of the change. There is a facility on EToN to do so.

If the road works have not started within six months of the proposed start date, or within six months of the completion of any undertakers' works that were carried out as a result of the notice, the notices ceases to be valid. A restriction will not be created and the process would need to be repeated.

Once the substantial road works are completed, the street authority should give a further non-statutory notice to the parties mentioned above stating that the works have been completed and that the restriction is in force. This action should be prompted by the highway authority's own Works Closed Notice. Once the restriction is in force, street works may only be undertaken in the street as detailed in 6.5.

### **6.3.2 Creating a restriction under section 58A**

On receipt of a notice under section 54 of NRSWA, a Highway Authority wishing to impose a restriction following Substantial Street Works should:

- (a) Identify other works that it already knows about that should also be completed before the restriction comes into force.
- (b) Publish a notice of its intention to create a restriction on its website, giving at least 20 days notice of its intention to create a restriction. The notice must describe the proposed works and give the date when they are proposed to start; state the duration of the proposed restriction and the part of the highway it will affect; and

require any other undertakers proposing works who have not given notice, to do so within the 20-day period.

(c) Copy the notice to:

- any sewer, transport or bridge authority with an interest in the street
- anyone who has given advance notice of intended works
- anyone with apparatus in the street
- anyone who has registered an interest in that street
- the occupiers of any premises which have a frontage onto the street in question.

(d) Place a copy of the notice on the register.

(e) Place a copy on any central registers.

Copies of notices should be given electronically or by post, where appropriate. Authorities may also wish to publish proposed restrictions in local newspapers.

Works promoters must reply to such notice received from street authorities within the 20 days notice period.

At the end of this period, the street authority will know of the proposals of the first works promoter; of any works promoter who gave notice in response to the street authority's notice; and of any other works promoter who has co-incidentally given notice of its intention to work in that part of the highway.

By way of co-ordinating those works, the street authority may now give directions stating when each of those works may begin. Street authorities should do this as quickly as possible.

No other works promoter may now begin any works (other than exempted works or works to which an authority has given consent see 6.5.3) in that part of the street until all the works referred to in the last paragraph have been completed.

After the end of the notice period and before all the works have been completed, the street authority may give a direction imposing the restriction by publishing on the website. It must copy the direction to all the parties to whom it gave its original notice and place a copy on the register.

### **6.3.3 Revocation of a restriction under s58A**

A restriction may be revoked at any time. The procedures for doing so follow the same principles as those outlined in 9.4. There are no powers to vary a restriction under s58A

## **6.4 Duration of Restrictions**

### **6.4.1 Duration of restrictions**

Durations of restrictions depend upon the type of works carried out and the impact they have on the travelling public and the local neighbourhood. Longer restrictions will apply where streets, or parts of streets, have been newly constructed, reconstructed or

resurfaced, as set out in Table 6.1.

<b>Table 6.1: Maximum durations of restrictions</b>		
Works type	Category of carriageway in street	
	Traffic-sensitive or reinstatement category 0, 1 & 2	Reinstatement category 3 & 4
1: Reconstructed	5 years	5 years
2: Resurfaced with or without level change	3 years	3 years
3: Other substantial road or street works	1 year	6 months
Combination of 1 or 2 plus 3	Higher of figures	Higher of figures
Customer connections	20 days	
<b>Definitions used:</b>		
<i>Reconstruction is the removal and replacement of some or all of the various layers that make up a road pavement. It is used to strengthen the road pavement.</i>		
<i>Resurfacing is the removal of the running surface and its replacement to restore surface integrity and skid resistance.</i>		
<i>“Other substantial road or street works” refers to the effects of substantial street works and substantial road works, such as drainage provision, which leave similar reinstatements to those after undertakers’ works.</i>		

## 6.5 Works during a Restriction

Works may be carried out during a restriction if the works either fall within the categories of exempt works or have the consent of the street authority.

### 6.5.1 Exempt works and reduced restrictions

Works which are exempt or subject to reduced restrictions are:

- minor works that do not involve breaking up or excavating in the highway
- immediate works
- customer connections (see 6.5.2)
- works to comply with either an improvement notice or prohibition notice issued by the Health and Safety Executive under sections 21 or 22 of the Health and Safety at Work, etc 1974
- works carried out under regulation 16(3)(b) of the Gas Safety (Installation and Use) Regulations 1998
- works carried out to comply with a programme approved under Regulation 13A of the Gas Pipelines Safety Regulations 1996 (SI1996/825, as amended by SI2003/2563) that could not have been identified before the restriction began.

The normal noticing rules appropriate to the works concerned must be followed (but note also 8.4.2).

### **6.5.2 Customer connections**

If an undertaker receives a request for a new customer connection after the period for response to a section 58 or section 58A notice of restriction, and it is not possible to carry out the necessary works before the restriction comes into force - then an embargo on carrying out those works will apply for 20 working days (date restriction begins plus 19 days) immediately following the completion of the substantial street or road works, as indicated in Table 4.

Before issuing the appropriate notice the undertaker must contact the street authority to discuss its proposals and the extent of the works in the street. The notice must contain the information discussed, the fact that it is a customer connection, and the name of the street authority officer who has confirmed the proposal.

It is expected that the minimum works will be carried out to provide the connection but it should be recognised that in some circumstances, extra work may be required to minimise disturbance to the restricted surfaces.

### **6.5.3 Other works during a restriction**

If the proposed works do not fall within one of the exempt categories, then the works may be carried out, but only with the street authority's consent.

An application for consent should be made, in writing, specifying, in addition to the standard street works information, the grounds upon which consent is sought. Once consent is granted, notice must be given as normal. The street authority should respond to an application for consent within 20 days of receipt. The undertaker cannot start work without receiving the consent of the street authority. Consent should not be unreasonably withheld. If the street authority refuses consent and the undertaker considers this unreasonable, the matter may be settled by arbitration.

The exemptions described in 6.5.1 exemplify the balance that must be achieved if the co-ordination aspects of the legislation are to be successful. In considering applications for consent from works promoters, street authorities must take account of the needs of the promoter's customers. Equally, works promoters must recognise the needs of road users and the need to ensure best value for money in highway expenditure. The key test is whether the undertaker could reasonably have foreseen the eventuality during the notice period and/or could reasonably be required to postpone the work until the end of the restriction.

Undertakers should do their utmost to give details of their plans for works in affected streets as early as possible within the notice periods, and to complete their works before any specified starting date or in accordance with directions. Nevertheless, if works overrun, or have to be carried out after the specified date, it would be sensible from the point of view of road users for these street works to be accommodated before completion of the substantial works concerned.

## **6.6 Policy Guidance**

The appropriate use of restrictions will not only protect streets where notice is served, but

should also encourage highway authorities and undertakers to plan and amend their programmes in a way which minimises inconvenience for the public.

If a street authority wants to prevent works occurring in a newly constructed or improved road, it should use the powers available under section 61 of NRSWA, to designate the road as a protected street from the date of its opening to traffic.

A restriction under section 58 or section 58A cannot be made, if substantial works have started without a notice under section 58 or section 58A having been given. However, even if works promoters are not aware of a restriction, they are strongly recommended to approach the authority to establish whether a restriction is in force, when a street, in which it is proposed to carry out works, has been newly constructed, recently reconstructed or resurfaced. Works promoters should not assume that they can automatically break open that street. It may be that the ASD entry has not yet been posted, or that a particular works promoter was not sent the relevant notice under s58 or s58A and there may be a restriction in force.

If having received a notice, the authority realises that there is a restriction in place then they should advise the works promoter of this fact as soon as possible.

## **6.7 Dispute Resolution**

Disagreement between the works promoter and the street authority should be resolved by means of the dispute resolution procedures set out in Chapter 13.

## **7 WORKS CLASSIFICATION**

### **7.1 Works Promoters**

A works promoter can be either an 'undertaker' or an 'authority':

#### **7.1.1 Undertakers**

An 'undertaker' - as defined in section 48 (4) of NRSWA - refers to:

- (a) a person with a statutory right to keep apparatus in the street and to carry out necessary works or
- (b) a holder of a street works licence.

#### **7.1.2 Authorities**

A 'street authority' - as defined in section 49 (1) of NRSWA - is either:

- (a) the highway authority for a maintainable highway or
- (b) the street managers of a private or non-publicly maintainable street.

'Other authority' - as defined in sections 88, 89 and 91 of NRSWA - is a sewer, bridge or transport authority.

### **7.2 Street Works Licences**

A street authority may grant a street works licence. This allows a person without a statutory right, to place, retain and remove apparatus in the street, and to do work necessary for that purpose. The licence system is governed by section 50 of, and Schedule 3, to NRSWA.

#### **7.2.1 Notice requirements**

The street authority must give at least ten days notice to undertakers and others likely to be affected before issuing a licence.

The licensee must give the street authority notice of the proposed start date before beginning work, following the same notice periods as for other street works. See section 7.5.1. The street authority should remind the licensee of this requirement and to whom it should copy such notifications.

#### **7.2.2 Record keeping**

A street authority must keep a record of all street works, and apparatus installed, under licences it has granted. Details of licences must be included in the street works register.

#### **7.2.3 Obligations on licensee**

The street authority should inform the licensee and the licensee's agent, where applicable, of its obligations under NRSWA, regarding:

- safety, signing, lighting and guarding



- qualifications of operatives and supervisors
- delays and obstructions
- other undertakers' apparatus
- reinstatement
- records of apparatus; and
- the needs of people with disabilities.

The street authority should also inform the licensee:

- of the restrictions on streets subject to special controls
- of relevant section 58 and 58A notices
- that it may direct working times and recover its inspection costs.

The licensee should also be made aware of the requirements of section 74 of NRSWA.

Reinstatement specifications and guarantee periods will be the same as those for other street works undertakers.

The licence can include many of the matters above as conditions of consent.

## **7.3 Registerable Works**

7.3.1 Registerable works include:

- street works - work on plant and apparatus in the street by undertakers, and noticed by them under section 54, section 55 or section 57 of NRSWA
- works for road purposes - maintenance and improvement works to the road itself carried out by, or on behalf of, the highway authority; and
- major highway works.

A detailed description can be found in the Technical Specification for EToN.

7.3.2 All works covered in 7.3.4 have to be registered. The street authority shall record works notified by undertakers in accordance with the regulations and Chapter 8 of this Code. Works, which are not notified in this way, are unlikely to be picked up by the street authority. It follows that only those works, which are notifiable, will in fact be registerable. Although the definitions are different legally, to all intents and purposes they are the same thing in practice.

NRSWA does not require local authority road works to be notified in the same way, although they do need to be registered. It is strongly recommended that the same process is used.

7.3.3 The street authority's network management duties require it to hold information on the works and activities carried out on its street network. Registering road works is the first and most important step to achieving that.

7.3.4 Works promoters must register, or notice, all works that:

- (a) Involve the breaking up or resurfacing any street, (see below for pole testing involving excavation).
- (b) Involve opening the carriageway or cycleway of traffic sensitive streets at traffic sensitive times.
- (c) Require any form of temporary traffic control as defined in the *Code of Practice for Safety at Street Works and Road Works*.
- (d) Reduce the lanes available on a carriageway of three or more lanes.
- (e) Require a temporary traffic regulation order or notice, or the suspension of pedestrian facilities.
- (f) Require a reduction in the width of the existing carriageway of a traffic-sensitive street at a traffic-sensitive time.

Works promoters do not need to register:

- **traffic census surveys** – because disclosure prior to a census can encourage a change in normal traffic flows
- **pole testing involving excavation** - does not require registration, unless one or more of rules (b) – (f) above, apply. However the work must be registered within ten days of completion
- **road markings** - that are not part of a larger set of works and do not reduce the width of the carriageway, as they do not involve breaking up of the highway.

### 7.3.5 Bar holes

Bar holes are used to detect and monitor gas leaks. Those which require no further street works, such as a reported gas leak with none detected should be registered within ten days of final monitoring checks. For registration purposes, bar holes count as a single excavation and reinstatement.

An immediate (eg emergency) notice must be sent within two hours of the start of any other registerable street works (i.e. excavation, or activities defined in 7.3.4) associated with the bar holes. For registration purposes, these bar holes will not count as further excavations and reinstatements.

All bar holes must be reinstated and registered when works on site are complete.

## 7.4 Street Authority Works for Road Purposes

### 7.4.1 General information

Section 53 of NRSWA requires an authority to place information about its own works on the street works register and this should be done in similar timescales to undertakers. The Regulations specify that this applies to works that involve

- breaking up any part of the highway
- opening the carriageway of traffic sensitive streets at traffic sensitive times or

- reducing the width of the carriageway by one or more lanes, or by more than one-third.

Therefore works equivalent to those carried out by undertakers will be registered, as set out in 7.3.4. Registration identifies responsibility for the works and underlines the importance of advance notification. This is essential for planning and co-ordinating works so that they limit both disturbance of the road structure and disruption to users.

In effect, highway, transport and bridge authorities are giving notice of their proposals to all other parties. They should therefore use the protocols in the Technical Specification for EToN for notices for this purpose. In general, these works will use similar classification criteria as those for street works.

Registration is not required for road markings and similar works that do not involve breaking up or reduce the width of the carriageway.

#### 7.4.2 Street lighting

The definition of works for road purposes may include some works carried out by undertakers, such as street lighting. It is for works promoters to ensure such works are notified or registered, as appropriate. Responsibility for new connection works to the street authority asset resides with the street authority.

Fault repairs and works carried out for any other authority, such as District or Parish Councils, are not works for road purposes. They should be treated as street works and must follow the normal procedures.

### 7.5 Categorisation of Works

Works are categorised by duration, except for immediate works, which are not time specific.

#### 7.5.1 Notice periods

<b>Table 5. Minimum notice periods</b>			
Works category	s 54	s 55	s 57
Major	3 months	10 days	n/a
Standard	n/a	10 days	n/a
Minor	n/a	3 days	n/a
Immediate -- Urgent	n/a	2 hours after	n/a
Immediate -- Emergency	n/a	n/a	2 hours after

Whenever possible, longer notice should be given. Undertakers should contact the street authority early in their planning cycle so that they are aware of any directions or restrictions that may affect works.

Where a section 55 notice is still valid for the works concerned, a further section 55 notice cannot be given for the same works. See 8.2.2.

An assessment tool, which identifies works likely to cause significant disruption, can be found in section 12.7 and Appendix G.

## **7.5.2 Major works**

### **Definition**

Major works:

- have been identified in an undertaker's annual operating programme or, are normally planned or known about at least six months in advance of the proposed start date
- require a temporary traffic order (not a temporary traffic notice) under the Road Traffic Regulation Act 1984 for any works other than immediate works. See section 12.1 or
- have a planned duration of 11 days or more, other than immediate works.

### **Notice periods**

Under Regulations undertakers are required to give three months notice of major works (Section 54) and a 10-day notice of starting date (Section 55).

## **7.5.3 Standard works**

### **Definition**

Standard works are works, other than immediate or major works, with a planned duration of between four and ten days inclusive.

### **Notice periods**

Standard works require a 10-day notice of starting date (section 55).

## **7.5.4 Minor works**

### **Definition**

Minor works are works, other than immediate or major works, with a planned duration of three days or less.

### **Notice periods**

The notice requirement for minor works is a three-day notice of starting date (section 55).

## **7.5.5 Immediate works**

### **Definition**

Immediate works are either:

- emergency works, which are defined in section 52 of NRSWA, are works required to end, or prevent, circumstances, either existing or imminent, that might cause damage to people or property. The term includes works that do not fall within that definition but which cannot be severed from those that do. An example is street works away from an emergency site that are necessary to shut off or divert a supply. Remedial works to dangerous, defective reinstatements are classed as emergency works (see 7.6.1) or
- urgent works as defined in the Regulations as street works:
  - (a) (not being emergency works) whose execution is required (or which the

person responsible for the works believes, on reasonable grounds, to be required):

- (i) to prevent, or put an end to, an unplanned interruption of any supply or service provided by the undertaker
- (ii) to avoid substantial loss to the undertaker in relation to an existing service or
- (iii) to reconnect supplies or services where the undertaker would be under a civil or criminal liability, if the reconnection is delayed until after the appropriate notice period; and

(b) includes works that cannot reasonably be severed from such works.

### **The notice requirement**

Immediate notices must be given as soon as reasonably practicable and, in any event, within two hours of the works starting. Where immediate works are identified and undertaken outside the normal working day the notice should be given within two hours of the start of the next working day, i.e. by 10:00.

Urgent works require a section 55 notice; emergency works require a section 57 notice.

Notices of Immediate Works must explain why they fall within the definition.

### **Burden of proof**

If a street authority disputes whether works, or part of works, is immediate, the undertaker must demonstrate conclusively that it is. Elements of work, which could be subject to the normal notice period, cannot be included in the 'immediate' category.

### **Severable works**

The definition of emergency works in section 52 of NRSWA provides that items of work which "cannot be reasonably severed" from the emergency works are regarded as part of them. The same test applies to urgent works.

Works which can be "reasonably severed" from the immediate works must therefore be regarded as separate works and classified as appropriate.

Typically, immediate works shall consist only of a repair to end the emergency, or restore the service, and complete the necessary reinstatement. Subsequent works to provide a permanent solution are "severed" and subject to a separate notice.

If the undertaker leaves site after dealing with the immediate problem, including carrying out an interim reinstatement and closing down the site, and returns later for further works - it is clear that these are "severed". However, even where works are continuous, the later stages are not necessarily part of the immediate works.

See 2.9.1 for notices and phasing where immediate works are followed by subsequent works.

## 7.6 Remedial Works

### 7.6.1 Definition

Remedial works correct defects identified in accordance with the *Code of Practice for Inspections and Regulations* (2<sup>nd</sup> October 2006).

The type of notice for these works (sections 55 or 57, and all section 74 notices) will depend on whether they can also be categorised as major, standard or minor works. They should use the original works promoter reference number. Those remedial works to remedy dangerous defects will, of course, be categorised as immediate works.

**The procedures below outline how an undertaker notifies a street authority of remedial works. They do not affect the power of the street authority to remove a danger arising from a defective reinstatement.**

### 7.6.2 Noticing requirements

The noticing requirements for remedial work to an interim or a permanent reinstatement are the same as those for all other types of street works.

To assist co-ordination, the notice should use the original works reference number. If the original works notices cannot be found, a new works reference number will be needed, highlighting that these are remedial works. A section 54 notice is not necessary for remedial works.

Under section 72(3) of NRSWA, an authority can require remedial works to be carried out within seven days or such other periods as may be prescribed.

If the undertaker discovers the necessity for remedial works the following action should be taken:

- if the reinstatement is dangerous, the undertaker should take the necessary action and inform the street authority by way of an section 57 notice or
- for all other remedial work, the undertaker should agree the works and timings with the highway authority, before notifying the street authority, (see section 2.8).

The undertaker is encouraged to make the interim reinstatement of the original works permanent while carrying out remedial works.

If the street authority discovers the necessity for the remedial works the actions set out in the *Code of Practice for Inspections and Regulations* (2<sup>nd</sup> Oct 2006) should be followed.

All the other notices that are required for works will also be required for remedial works.

### 7.6.3 Purpose of the notices

The purpose of the notice is two-fold. It enables the street authority to co-ordinate the work and allows it to inspect the works in progress and on completion.

This paragraph should be read alongside the requirements of section 72 of NRSWA and the *Inspections Regulations* and *Code of Practice for Inspections*.

## 8. NOTICE REQUIREMENTS AND VALIDITY

### 8.1 Introduction

This chapter describes the various notice requirements of NRSWA. For the purposes of this Code of Practice, works include highway works and street works.

The notice system performs at least seven functions:

- it is a vital component of the co-ordination process
- it enables emergency notices, which can prompt the emergency procedures of other organisations
- it triggers the inspection regime
- it forms the basis of records for reinstatement guarantee purposes
- it records who has worked at a particular location
- it facilitates charging regimes; and,
- it is an essential element of the street authority's responsibility for keeping a register.

The term "notification" includes notices, notifications, registrations of reinstatement, directions, responses, and cancellations.

An undertaker starting work in a new area should advise the street authority of its DfT code (sometimes referred to as the DETR code) and operational district (see the Technical Specification for EToN), at least 20 days before serving the first notification and would be advised to check the street works Register. However, it may be helpful to new undertakers in an area, if the authority brought to their attention any restrictions or designations.

Others proposing to carry out work for the first time may not be aware of the requirements of the legislation and this Code. They are likely to contact the local authority. All such contacts should be referred to the authority's Traffic Manager (appointed under section 17 of the TMA) or street works manager, as appropriate. However, it is recognised that most other activities on the highway are controlled by other statutory provisions that may not include the giving of notices.

Works for road purposes need to be registered (see section 7.3.4), and street authorities should consider providing notices in a similar form to those required for street works.

### 8.2 Notice Types

NRSWA provides for different types of street works notice:

#### 8.2.1 Advance notice (section 54)

Major works, require an advance notice under section 54 of NRSWA as amended by section 49 of the TMA. To promote co-ordination, the notice must include all available information about works in that street, including an estimated end date and a cross

reference to any project of which the works are part. Details can be found in the Technical Specification for ETON.

### **8.2.2 Notice of starting date (section 55)**

Undertakers shall notify the street authority of all registerable street works in accordance with section 55 of NRSWA - including major works for which a section 54 notice has already been submitted. The notice must include all available information about works in that street, including an estimated end date, and be cross-referenced to any project of which the works are part. Details can be found in the Technical Specification for ETON.

This prevents works being split into smaller units requiring a shorter notice period.

No notice is required for works that do not involve breaking up the street or tunnelling or boring (for undertakers this would be mainly openings), in the following circumstances:

- in a street that is not designated as traffic sensitive
- in the footway of a traffic sensitive street at any time or
- in the carriageway of a traffic sensitive street outside traffic sensitive times.

Within the notice period, the undertaker must indicate whether he intends to work outside the normal working day (see section 98 (2) of NRSWA). This information will be used by the street authority in respect of its powers under section 56 to direct when works may take place. However, this provision does not prevent an undertaker working at weekends or at night if the works require it once they have commenced, provided that the undertaker advises the authority of the need and reasons for doing so.

### **8.2.3 Immediate works notice (sections 55 or 57)**

An immediate works notice is:

- (a) In emergency works - a notice under section 57 of NRSWA or
- (b) In the case of urgent works - a notice indicating start of works under section 55 of NRSWA.

Immediate works notices may be given as soon as reasonably practicable and, in any event, within two hours of the works starting. If the authority to whom an undertaker is obliged to give such notice does not have arrangements for receiving and responding to notices 'out of hours' (any period between 16:30 and 08:00 the following day), the undertaker shall have complied with his obligation if he serves a notice by 10.00 on that the following day.

### **8.2.4 Actual Start (Sections 74 (5B) and 74 (5C))**

The validity period, covered in 8.4, means that works do not have to start on the date proposed in the section 55 notice. Therefore, notification of the actual start date is required to begin the prescribed or reasonable period. Works may not begin before the date given in a Notice of Proposed Street Works, unless an early start date has been agreed.

Once works begin, a Notice of Actual Start must be given by the end of the next working day. In the case of immediate works, the notice given under section 57, for emergency works, or section 55, for urgent works, shall be deemed to be the Actual Start Date notice. This is because it can be given up to two hours after the works have commenced



A notice of Actual Start must be given in accordance with the requirements described in the Technical Specification for EToN

The identity of the main contractor or, if appropriate the Direct Labour Organisation ("DLO"), must be provided on the actual start date notice. This should always be the organisation with whom the undertaker has the contract, and not any subcontractor who may be actually carrying out the works.

### **8.2.5 Revised Duration Estimate**

Unforeseen circumstances can delay the completion of works, so the undertaker may give a Notice of Revised Duration Estimate at any time before the estimated end date. Such estimates should provide full justification for the extension.

### **8.2.6 Challenge to Duration Estimate**

A highway authority may dispute a duration estimate, in a section 54, 55, 57 or 74 notice, or a revised duration estimate. It can give the undertaker its own estimate using a Duration Challenge Notice (section 74 (4) of the Act). See Technical Specification for EToN.

The Duration Challenge Notice must be sent within two days of receipt of the Duration Estimate or Revised Duration Estimate for minor works and within five days for major or standard works.

If the undertaker does not accept the challenge of duration it must notify the highway authority within two days, using a non-statutory Duration Challenge Non-acceptance Notice. See Technical Specification for EToN. If the following discussions, or dispute resolution procedures, lead to a duration estimate different from that in the highway authority's duration challenge, the undertaker must issue a Revised Duration Estimate.

Records will have to be altered manually if the dispute has passed the expiry of the reasonable period.

### **8.2.7 Works Clear (Section 74 (5C))**

A works clear notice is used following interim reinstatement. The Notice of Works Clear must be given by the end of the working day following the one on which the works were clear. There may be multiple works clear notices in works of more than one phase. The completion of an interim reinstatement does not mark the end of that phase, as all spoil, excess materials, stores, signing, lighting and guarding must be removed from site before the works can be regarded as completed for a works clear notice.

### **8.2.8 Works Closed (Section 74 (5C))**

A works closed notice is used following permanent reinstatement. The Notice of Works Closed must be given by the end of the working day following the one on which the works were closed.

All spoil, excess materials, stores, signing, lighting and guarding must be removed from site before the works can be regarded as completed for a works closed notice.

If temporary road markings have been used, the works are not complete until the permanent markings are applied. The works duration should also cover this period.

### **8.2.9 Duty to maintain apparatus**

See Section 12.2

### **8.2.10 Diversionary Works (Section 84 notices)**

Regulations under section 84 (1) of NRSWA allow a highway, bridge or transport authority to notify undertakers of major highway, bridge or transport works. Details of the procedure can be found in the *Code of Practice for Diversionary Works*.

### **8.2.11 Notice of completion of reinstatement**

Section 70 of NRSWA requires an undertaker to notify a street authority within ten days of completing a reinstatement. The notice must state whether the reinstatement is interim or permanent. It must also contain the following:

- NGRs either
  - i. one in the centre of small excavations or
  - ii. one at each end of trenches
- the dimensions and description of each and every reinstatement
- the date the site was reinstated, which is the start date for the guarantee period
- the reinstatement construction method for all the reinstatements carried out.

The notice could also include the following:

- the number of inspections units
- an illustration, which may be a plan, sketch or digital photograph, may also be provided.

### **8.2.12 Time for completion of permanent reinstatements**

An undertaker must complete the permanent reinstatement as soon as reasonably practicable, and in any event within six months of the completion of the interim reinstatement. A further notice must be given as above within ten days of completion of permanent reinstatement.

A further set of notices are required to complete works from interim to permanent reinstatement stage. These must start with a new section 55 notice of proposed start date, but must use the same works reference as that used for the first phase of works to interim reinstatement stage. This ensures continuity of notices through the whole life cycle of the works. The works promoter must ensure that the notice to register the interim reinstatement has been given before attempting to give notice of works to complete the permanent reinstatement. The EToN system will not accept a section 55 notice for permanent reinstatement before the interim reinstatement has been registered. There is a similar requirement for remedial works.

## **8.3 General Rules Applying to all Notices**

### **8.3.1 Method of giving notices**

Notices may be given electronically or in paper form and must comply with the requirements set out in the Technical Specification for EToN. For this purpose only, a notice given by fax is regarded as a paper notice and must comply with the conditions set out in that specification. Paper notices are subject to a registration fee in accordance with *The Street Works (Registration Fees) (Regulations) 1999, SI 1999, No. 1048*.

The regulations include a sunrise provision of April 2009 for all statutory undertakers and street authorities to move to an all-electronic noticing system that conforms to the Technical Specification for EToN.

Other activity promoters, such as those operating under section 50 of NRSWA, will be encouraged to move to an electronic system within five years of the publication of this Code. Authorities may wish to provide facilities to allow on-line provision of information by those operating under section 50. After this, paper notices i.e. by fax, post or hand delivery will be allowed only if the electronic process is unavailable.

Recipients of certain notices or copies of notices, eg transport authorities or frontagers, are unlikely to have access to EToN and therefore notices will have to be given either by e-mail or more likely by post.

### **8.3.2 Content of notices**

The definitive format and content of notices is given in the Technical Specification for EToN, and all notices must comply. Anyone using paper systems must take particular care to code notices appropriately.

The description of works should be in plain English without any industry specific jargon. A standard description used consistently, with added text for exceptions, allows quicker analysis. This would result in clearer information and help street authorities to co-ordinate works.

For instance standard descriptions and durations might be:

- Standard descriptions – for example, '250m lay main 300PE', or, '700m lay duct 6-way' and,
- Standard durations – in days, for each activity.

Undertakers and highways authorities are encouraged to agree standard descriptions locally that can be used by all works promoters.

Agreed standard durations for routine jobs would help focus co-ordination on those works likely to be of greater impact, such as those in busy streets or works that need extending.

### **8.3.3 Duration of Works**

All notices should estimate start and end dates so that the duration can be calculated.

For section 74 purposes the estimated duration of works is measured from the start date to the end date given in the notice of actual start. However, the actual duration used to assess whether works have overrun - is measured from the notice of Actual Start to the

completion of all activities in that phase of works, including any necessary reinstatement. See 8.2.4, 8.2.7 and 8.2.9.

Interim and permanent reinstatements are separate phases. See 2.9. The period between these cannot be considered as an overrun provided the site has been properly cleared. All spoil, excess materials, stores and all signing, lighting and guarding should be removed from site before works can be regarded as finished.

Further works to complete the reinstatement, for example the replacement of road markings where delay is permitted by the specification, should be a separate phase.

### **8.3.4 Days and working days**

Unless stated otherwise, in this Code “day” means “working day”, which is defined in section 98(2) of NRSWA, as any day except weekends and public and bank holidays. The working day is defined as 08:00 to 16:30. Any notice received after 16:30 on any day is deemed to have been given on the next working day.

The time of 16:30 is significant only for calculating notice periods. It does not mark the “end” of the day for any other purposes.

The estimated start and end dates given in notifications can be working or non-working days. Promoters should specify the actual dates on which they intend to start and end the works in order to assist co-ordination. Authorities may or may not allow works to be carried out on non-working days (and outside normal working hours) depending on local circumstances.

### **8.3.5 Service of notices**

The notice period starts when the recipient receives the notice, not when it is sent.

Notices should be served on the street manager of private streets, which are public highways. A copy should be sent to the highway authority for registration.

With electronic transfer receipt is normally almost instantaneous and it is assumed a notice has been received at the time it was given, unless there is evidence to the contrary. It is good practice to set up audit trails, to demonstrate proof of writing, and systems to record delivery.

A new EToN system based on XML web services has been implemented in conjunction with the publication of this Code and the Regulations (see the Technical Specification for EToN). Statutory undertakers and local authorities may provide a different address for specific type of notice. It should be noted that electronic transfer of inspections data will continue to use EToN 3.0 for the time being.

Where, after three attempts to give a notice by EToN (duly recorded by the person serving the notice), the notice cannot be given (for example because the distant server is down), notification should be given by telephone or fax for immediate works with formal EToN notice following as soon as reasonably practicable. For other notices, the notice may be given by other electronic means (eg e-mail or fax) or may be sent by post or delivered or by any other method agreed. Following recovery of service a copy of the notice should then be sent through EToN to ensure information on the works are correctly recorded in the register. See Technical Specification for EToN

It is recommended that street authorities include in their ASD alternative means for serving notices should the XML web server be unavailable. These may include e-mail addresses, or fax and phone numbers, or postal and delivery addresses, as appropriate. Statutory undertakers may wish to provide alternative addresses to use should EToN be unavailable in their ODD submissions.

If notices are sent by fax, it is assumed that a notice has been received when the transmitting equipment records satisfactory completion of the transmission.

It is not guaranteed that notices sent by first-class mail will be received the following day. Promoters should take this into account.

### **8.3.6 A Notice shall contain only one street**

Each notice shall contain information about works in only one street. However, works may be part of a larger project and cross-referencing all the notices related to one project would be useful for co-ordination.

### **8.3.7 Phases**

Where the notice relates to work that may be completed in phases, the estimated end date is the estimated date of the end of that phase. A new notice will be required to start the next phase. However, each phase is part of the same works, and the protocols in the Technical Specification for EToN should be followed.

### **8.3.8 Notices to interested parties**

Some notices have to be served on other interested parties as do any responses to them. The ASD, associated with the NSG, makes it clear where this applies. Electronic systems working with the Technical Specification for EToN should deal with this automatically. Interested parties without access to these systems should be sent paper notices.

### **8.3.9 Early starts**

Works must not start before the expiry of the notice period, except where an early start has been agreed with the street authority and any other interested parties. For instance, there may be works that while not meeting the criteria for immediate works, would be better carried out sooner rather than later to prevent damage, eg. water leaks or to allow new customer connections to be made. Permission should not be refused unreasonably.

Early starts may be requested by undertakers prior to, or following, the serving of section 54 or section 55 notices. Where an early start has been agreed the promoter shall include on the next notice:

- the early start date
- reasons for the early start
- the name of the person granting permission and
- the new proposed end date.

This notice would be either the s55 notice, where the early start has been agreed following section 54 notice or more usually the section 74 Actual Start Date notice following a section 55 notice.

### **8.3.10 Protected streets**

Consent to place apparatus in protected streets is required by section 61 of NRSWA. This must be obtained before giving the statutory notice, so that there will be no need to cancel the notice if the works are not approved.

### **8.3.11 Trench sharing**

With trench sharing, the primary promoter should take overall responsibility as the agreed point of contact with the street authority. The secondary promoter(s) should retain the same responsibility for submitting notices, in accordance with NRSWA, indicating work carried out by them or on their behalf. For example, the primary promoter will excavate the trench and install its apparatus. The secondary promoter will then install its apparatus. Finally, the primary promoter will backfill the trench and reinstates it, unless it has agreed that one of the secondary promoters will do it.

Only those notices submitted by the primary promoter are required to show the estimated inspection units attributable to the street works. The primary promoter must, in the initial notice, detail the other promoters involved and the scope of trench sharing, in the Works Description text. All other promoters should submit the correct notices and clearly mark, that “trench sharing is involved” within the Works Description text. The secondary promoter’s notice will indicate only the laying of apparatus.

The primary promoter must also ensure that estimates of works duration are agreed and/or confirmed with the secondary promoter(s) when submitting notices to comply with section 74 charging requirements.

### **8.3.12 Streets of special engineering difficulty (SED)**

In addition to giving statutory notice of works, promoters must comply with the provisions of Schedule 4 to NRSWA before work starts, including the submitting and agreeing the plan and section of works with the relevant authorities (for example where appropriate the transport authority, as well as the street authority) at the appropriate times.

The requirements of schedule 4 override those of section 54 so it may be necessary to cancel a section 54 notice if SED approval is not forthcoming.

To avoid delaying works, promoters should allow enough time to obtain SED approval.

### **8.3.13 Road closures and portable light signals**

In addition to the above notices, road closures, portable light signals, or other measures required under the Road Traffic Regulation Act 1984 must comply with regulations<sup>6</sup>. See 12.1

Sufficient time must be allowed before works start for the processes to be completed, and the closure or other restriction to be put into place during the validity period of the statutory notice. Additionally, undertakers should make it clear on notices that such requirements have been met or at least applied for.

---

<sup>6</sup> *The Road Traffic (Temporary Restrictions) Procedure Regulations 1992 SI 1992/1215*

### **8.3.14 Frontagers**

The highway authority is generally the first point of contact for complaints. The promoter should give advance information to frontagers about disruption to services and any restrictions on access, along with details of any mitigating action.

Any publicity should be copied to the highway authority.

Other users of the street should also be aware of what is proposed and the intended duration of the works. Local Authority websites can be useful (see 3.6.1), but courtesy notice boards are required at the site to inform motorists and passers by. These notice boards must comply with regulations<sup>7</sup> and the *Safety at Street Works and Road Works Code of Practice*.

### **8.3.15 Private or non-publicly maintainable streets**

For works in a private street, undertakers must copy notices served on the street managers to the street authority. They should also inform the frontagers. It is recommended that this is followed up by, or combined with, a formal letter giving the intended start date and explaining that the notification periods for publicly maintainable streets are applied to private streets. The impact on traffic can be calculated using the assessment tool in chapter 12 and appendix G. Other impacts, such as restrictions on access and loss of parking, can also be assessed.

### **8.3.16 Error correction**

Where an authority identifies an error in data recorded, or submitted for recording, in the street works register, it should contact the works promoter to discuss and agree the corrections.

Where the promoter identifies an error the recipient should be contacted to discuss and agree corrections. It is strongly recommended that the originator of an error should submit a non-statutory correction notice the next working day following agreement of the correction. This notice should include the corrected data and the name of the person in the recipient organisation who agreed the correction. The error correction process is described in the Technical Specification for EToN.

This procedure cannot be used without the prior agreement of both parties. Its purpose is simply to ensure that the information recorded in the register is correct and useful to the street authority in carrying out its co-ordination duties. The system has been set up so that the error correction sits alongside the original notice information rather than overwriting it.

## **8.4 Notice Validity**

### **8.4.1 Where advance notice has been given**

An advance notice (under section 54) must specify a provisional starting date. When the subsequent notice of proposed works (under section 55) is given, it must specify a start date, which is:

---

<sup>7</sup> *Traffic Signs Regulations and General Directions 2002 SI 3113 and Safety at Street Works and Road Works - A Code of Practice (ISBN 0 11 551958 0)*

- no earlier than three months after the date on which the advance notice is given, unless an early start has been agreed (see 8.3.9) or
- no later than 15 days beginning with the starting date given in the advance notice. A local authority may allow a further period of validity.

If the section 55 notice is not given as above then the provisions outlined in 8.4.4 come into force.

#### **8.4.2 Notice of proposed start date**

The works may not start earlier than the expiry of the notice period, except with the agreement of the street authority to an early start, see 8.3.9. However, the notice remains valid for the following time periods and therefore the works may start:

- in the case of a ten-day notice - no later than five days from and including the provisional starting date specified in the notice
- in the case of a three-day notice - before the end of the day after the provisional starting date specified in the notice. This may be such further period as the local authority may allow.

If the works have not started within these periods, the notice becomes invalid and a new notice of proposed start date should be given, unless the street authority agrees to extend the period.

A new advance notice is not required, providing that there is still time left within the validity period on the section 54 notice to give another section 55 notice; otherwise a new advance notice will be required.

#### **8.4.3 Immediate notices**

The issue of notice validity does not arise in the case of immediate notices because the works will have already started by the time the notice is issued.

#### **8.4.4 Notice cancellation**

If an undertaker decides, after giving notice, not to proceed with the works, it is essential that the notice is cancelled as soon as possible. For two reasons:

- a) Section 54 (4A) of NRSWA provides that if the undertaker has not issued a notice of intended start date under section 55 of NRSWA before the start date given in the s54 notice, then it must issue a notice informing the street authority information of its future plans for that work within two days of that date. The Technical Specification for EToN sets out the contents of this notice. The options are either that the work will never take place, or that it will take place but at a future date, in which case it will need to be reprogrammed.

If the works promoter wishes to carry out the work earlier than would be allowed if he had to submit the revised section 54 notice three months ahead of the proposal start date, then the notice should also request an early start (see 8.3.9). It should have a new works reference number. This section 54 (4A) notice should be given no later than the end of the next working day after the expiry of the section 54 (1)



notice in question.

b) If works have not started within the validity period prescribed in the regulations under Section 55 (7) of the section 55 (1) notice, then a further notice shall be sent to the authority providing such other information as may be required. This additional information shall be:

- the reasons for the works not starting
- whether the work is intended to start and when.

If the works promoter does not intend to proceed, the original notice should be formally cancelled. This section 55 (8) notice should be given no later than the end of the next working day after the expiry of the validity of the section 55 (1) notice in question. Any new section 55 (1) notice should use a different reference number.

If an undertaker decides voluntarily to cancel a notice, a further notice doing so should be sent as soon as possible. However, a formal cancellation is still required at the due time under s54(4A) and s55(8) and is reflected in the Technical Specification for EToN.

The provisions outlined above are described in more detail in the Technical Specification for EToN.

Failure to provide the new section 54 (4A) or section 55 (8) notices may result in a Fixed Penalty Notice being served on the promoter. See chapter 11.

<b>Table 8.1: Notice validity periods</b>					
	<b>Notice Periods</b>			<b>Notice Validity Periods</b>	
	<b>S 54</b>	<b>S 55</b>	<b>S 57</b>	<b>S 54</b>	<b>S 55</b>
<b>Major</b>	<b>3 months</b>	<b>10 days</b>	<b>n/a</b>	<b>15 days</b>	<b>5 days</b>
<b>Standard</b>	<b>n/a</b>	<b>10 days</b>	<b>n/a</b>	<b>n/a</b>	<b>5 days</b>
<b>Minor</b>	<b>n/a</b>	<b>3 days</b>	<b>n/a</b>	<b>n/a</b>	<b>2 days</b>
<b>Immediate – urgent</b>	<b>n/a</b>	<b>2 hours after</b>	<b>n/a</b>	<b>n/a</b>	<b>n/a</b>
<b>Immediate – Emergency</b>	<b>n/a</b>	<b>n/a</b>	<b>2 hours after</b>	<b>n/a</b>	<b>n/a</b>

## **9. DIRECTIONS**

### **9.1 Introduction**

This chapter covers the measures an authority can use to control works that it believes could cause serious traffic disruption.

Directions affect when and where an undertaker can carry out works in the street. NRSWA enables a street authority to serve two types of directions:

- Section 56 Directions – covering the times that works either proposed, or subsisting, can be carried out
- Section 56A Directions – covering restrictions on placing apparatus in the street.

NRSWA also enables an authority to reduce unnecessary delay or obstruction through a section 66 notice.

### **9.2 Section 56 Directions**

Section 56 of NRSWA provides for a street authority to serve a direction on an undertaker, setting out the dates and times during which proposed or subsisting works may be carried out.

#### **9.2.1 Proposed street works**

If an authority believes that major, standard or minor works, proposed via a section 54 or section 55 notice, will cause serious disruption, it can issue a section 56 direction before works start. See constraints below.

The assessment tool outlined in 12.7 and Appendix G should be used to assess likely disruption.

#### **9.2.2 Subsisting street works**

Once works have started, the street authority may issue a direction under section 56(1A). See constraints below.

In the case of major, standard and minor works, the direction should be issued only if circumstances causing serious traffic disruption have arisen after the works have started.

A direction under section 56(1A) may be used for immediate works at any time, provided that it does not result in danger to life or property. This is because immediate works will have started before the street authority will have had the opportunity to assess the impact of the works and use its power, if necessary.

#### **9.2.3 Constraints**

A section 56 direction is subject to four constraints:

- it cannot affect the right of an undertaker to execute emergency works
- it can be used only where proposed street works are likely to cause serious traffic

disruption that would be avoided or reduced if the works were carried out at other specific times

- it can be used only where subsisting street works are causing, or are likely to cause, serious traffic disruption that would be avoided or reduced if the works were carried out at other specific times; and
- a direction requiring street works to be executed out of normal hours should not be issued if it would cause the undertaker to breach noise abatement or prevention legislation. The custodian of this legislation may be different from the street authority.

Where it has directed works to be carried out at night, it is the street authority's responsibility to reach agreement with Environmental Health Officers on any resultant noise issues.

### 9.2.4 Dispute resolution

Guidance on dispute resolution procedures can be found in chapter 13.

## 9.3 Section 56A directions

Section 56A of NRSWA provides for a street authority to direct a works promoter not to place apparatus in the street, if it thinks that apparatus will cause serious traffic disruption. The authority may suggest an alternative street, but may not direct that the apparatus shall be laid in that alternative street.

### 9.3.1 Constraints

A section 56A direction is subject to three constraints:

- it applies only to new apparatus<sup>8</sup>
- it can be used only where disruption would be reduced by installing the apparatus in an alternative street
- it can be used only where it is reasonable to require the undertaker not to place the apparatus in the proposed street.

There is a right of appeal against the authority's direction.

The second constraint applies only to the disruption caused by the initial installation of the apparatus - see section 56A(1)(a). The street authority cannot include likely disruption over the life of the apparatus, such as that caused by maintenance visits.

The assessment tool outlined in chapter 12 and Appendix G of this Code enables a street authority to compare likely disruption for each option.

Constraint 3 is expressed in NRSWA as:

*"...placing the apparatus in [an alternative street] ... would be a reasonable way of achieving the purpose for which the apparatus is to be placed; and ... it is reasonable to*

---

<sup>8</sup> The Protected Street legislation (s 61 of NRSWA and s16 and s21 of Highways Act 1980) should be considered if the street authority wishes to have existing plant moved.

*require the undertaker not to place the apparatus in [the proposed street]..."*

The street authority can only judge how reasonable an alternative street is, after discussing the options with the undertaker. This discussion may lead the undertaker to modify its proposals, avoiding the need for a direction.

### 9.3.2 Policy guidance

Certain works are, by definition, not subject to direction under section 56A. These include maintenance works on existing apparatus and customer connections where there is no suitable alternative route.

To avoid a section 56A direction, undertakers should discuss preferred routes for apparatus with the street authority at the earliest opportunity in the design and planning process. It is therefore likely that this can be used only for major works.

## 9.4 Revocation of Directions

A street authority may revoke section 56A directions. It should inform the undertaker(s) via a revised section 56A notice – the Technical Specification for EToN explains how to do this. When revising directions, the street authority should use the same considerations as those used for the original direction.

## 9.5 Street Authority Responses

The street authority must respond within the times set out in Table 9.1 to a notice of proposed start date if it intends to give a direction under section 56 or 56A. This does not apply to a direction under section 56(1A).

A direction under section 56 or section 56A should be issued following receipt of a section 54 notice and not any subsequent section 55 notice, unless there have been significant change in the meantime. A direction following a section 55 notice would normally only be given, if this was the first notification of the proposed works.

	Notice Periods			Response Times for s 56 and 56A directions*		
	S 54	S 55	S 57	S 54	S 55	S 57
<b>Major</b>	3 months	10 days	n/a	1 month	5 days	n/a
<b>Standard</b>	n/a	10 days	n/a	n/a	5 days	n/a
<b>Minor</b>	n/a	3 days	n/a	n/a	2 day	n/a
<b>Immediate - Urgent</b>	n/a	2 hours after	n/a	n/a	*	n/a
<b>Immediate - Emergency</b>	n/a	n/a	2 hours after	n/a	n/a	*

\* Directions on immediate works may be given at any time before completion of the work.  
 ★ The above response periods do not apply when the direction under section 56 is given to allow street works to be completed before the introduction of a restriction under section 58.

## **9.6 Avoidance of Unnecessary Delay or Obstruction (section 66)**

Section 66 of NRSWA requires street works to be completed as quickly as possible.

If a street authority believes that an undertaker is causing an obstruction by occupying more of the street, or taking longer to complete the works, than is reasonable, it may issue a section 66 notice. This notice can direct the undertaker, either to reduce the obstruction or to remove it altogether. The undertaker must comply within 24 hours, or any longer period specified in the notice.

Good co-ordination should enable unavoidable obstructions and delays to be accommodated without the need for section 66 notices.

## **CHAPTER 10. Not used - Reserved**

## **11. FIXED PENALTY NOTICES**

### **11.1 Introduction**

This chapter provides information about the Fixed Penalty Notice (FPN) scheme for street works.

The fixed penalty notice scheme is introduced by section 41 of the TMA, which inserted section 95A and schedules 4A and 4B into NRSWA. It provides for certain offences, under Part 3 of NRSWA, to become fixed penalty offences.

The objectives of the FPN system are to:

- encourage accurate and timely notice data
- improve the co-ordination of works
- improve data quality for all works promoters
- contribute to the aim of the Traffic Management Act 2004 - minimising disruption arising from road and street works.

Fixed penalty notices:

- apply to all undertakers, whether statutory undertakers or licensees under section 50 of NRSWA
- may be given only for the street, or section of street, in which the works take place
- cannot be given for street authority works for road purposes.

Part 3 of NRSWA details a range of statutory duties and obligations and the offences associated with failing to comply with them. All of these can be prosecuted in the Magistrates' Court. It is for the street authority of the street concerned to take action on offences.

### **11.2 Fixed Penalty Offences under Part 3 of NRSWA**

At present, six offences, under Part 3 of NRSWA, can be dealt with by FPNs. However, the Welsh Ministers may make an order providing for offences to become (or cease to be) fixed penalty offences.

The scheme does not seek to impose new obligations and the offences included in this fixed penalty notice scheme remain the same offences and require the same level of evidence, whether they are dealt with by an FPN or through the Magistrates' Courts. The intention is to improve observance of the duties and obligations under Part 3, and thereby help reduce the disruption caused by street works.

An FPN offers an undertaker the opportunity to discharge any liability to conviction for a fixed penalty offence, by payment of a penalty.

However, the street authority retains the power to take an alleged offender to the Magistrates' Courts, instead of giving an FPN.

These offences refer to noticing failures. Therefore, payment of an FPN does not exempt an offender from other prosecutions or charges for offences under NRSWA.

It is important that accurate information is provided in notices given under section 54, 55 or 57, 70, 74. Each set of works requires several notices, so it is possible that more than one FPN could be issued for each set of works. However, only one FPN should be issued per notice regardless of the number of errors.

The table below summarises the duties and obligations to which the seven offences relate. All parties are strongly recommended to consult NRSWA, the TMA and the latest regulations for more information. It is not possible to state either what constitutes an offence, as that is a matter for the Courts or the circumstances in which an FPN may be challenged. Whether a particular case justifies giving an FPN or prosecution in the Magistrates' Court would be for each authority to decide based on the facts of the case and their own independent legal advice.



**Table 11.1: Summary of duties and obligations**

Offence	Brief description	Duties and obligations
An offence under s.54(5)	Failure to comply with duties under s.54	<p>In certain cases prescribed in regulations prescribed periods of advance notice must be given to a street authority by an undertaker proposing to execute street works.</p> <p>Each notice must state the proposed start date on which it is proposed to begin the works and contain the information prescribed in regulations.</p> <p>After giving <b>advance notice under s.54</b>, an undertaker must comply with the requirements prescribed in regulations, or imposed by the street authority. These concern, the provision of information and procedural steps to co-ordinate the works with other proposed works, of any description.</p> <p>If an undertaker who has given advance notice under s.54 has not, before the starting date specified in the notice, given to the street authority a notice under s.55 in respect of the works, he must within such period as may be prescribed in regulations [Regulation 8(3)] give to that authority a notice containing prescribed information.</p>
An offence under s.55(5)	Beginning to execute works in contravention of s.55	<p>In relation to certain types of street works an undertaker must give prescribed periods of <b>advance notice</b> stating the proposed start date and containing information prescribed in regulations.</p> <p>This notice must be given to the street authority, to any other relevant authority, and to any other person having apparatus in the street, which is likely to be affected by the works.</p> <p>The undertaker must not begin the works without notice, or before the end of the notice period, without the consent of those to whom notice is required to be given.</p>
An offence under s.55(9)	Failure to give notice in accordance with s.55(8)	<p>If the <b>notice of starting date</b> ceases to have effect, the undertaker must give a further notice containing such information as may be prescribed in regulations and within the prescribed period.</p> <p>This notice must be given to the same people as the notice of starting date (see <i>above</i>).</p>
An offence under s.57(4)	Failure to give notice in accordance with s.57	<p>Where emergency works are of a kind which either do, or would, but for certain provisions in Schedule 3A NRSWA, require a <b>notice of starting date</b> under s.55, an undertaker executing such works must give notice stating his intention or, as the case may be, the fact that he has begun to execute the works.</p> <p>The notice must also contain such other information as may be prescribed in regulations.</p> <p>The notice must be given as soon as reasonably practicable, and in any event within two hours (or such other period as may be prescribed), to the persons to whom a notice of starting date would be required to be given under s.55 (see <i>above</i>).</p>
An offence under s.70(6) consisting of a failure to comply with subsection (3) or (4A)	Failure to comply with requirements to give notice of completion of reinstatement	<p>S.70 (1) imposes a general duty on the undertaker to reinstate the street.</p> <p>The undertaker must, within ten working days from the date on which the reinstatement is completed, give notice to the street authority of that completion. The notice must state whether the reinstatement is permanent or interim, and give such other information about the reinstatement as may be prescribed in regulations.</p> <p>In the case of an interim reinstatement, the undertaker must within ten working days from the date on which the permanent reinstatement is completed, give notice to the street authority of that completion. The notice must contain such other information about the reinstatement as may be prescribed.</p>

<p>An offence created by regulations made under s.74(7B)</p>	<p>Failure to give a notice required by regulations under s.74 (<i>charge for occupation of the highway where works unreasonably delayed</i>)</p>	<p>The Street Works (Charges for Unreasonably Prolonged Occupation of the Highway) (Wales) Regulations 2008 will create a criminal offence in respect of any failure to give a notice required by the regulations.</p> <p>An undertaker executing street works in a highway, to which these regulations apply must, not later than the end of the day following the day on which the works begin, give the highway authority an “<b>actual start of works notice</b>”. This should confirm the actual start date and specify, by reference to the nationally consistent street gazetteer, the street or streets, in which the works are to be carried out.</p> <p>Once an undertaker has completed interim reinstatement, a written “<b>works clear notice</b>” must be given to the highway authority not later than the end of the day following the day on which the highway was returned fully to public use.</p> <p>An undertaker who has completed permanent reinstatement must give the highway authority a written “<b>works closed notice</b>” not later than the end of the day, following the day on which, the highway was returned fully to public use.</p> <p>If the duration of the works will exceed the prescribed period, a notice shall be given to the highway authority containing an estimate of the likely duration. The estimated duration of works should:</p> <ul style="list-style-type: none"> <li>• for works for initial placing of the apparatus, be given with the application for a licence</li> <li>• for other works (not emergency) be given with the section 55 notice</li> <li>• for emergency works be given as soon as practicable after the works begin.</li> </ul> <p>This estimate is assumed to be agreed by the authority, unless it gives a written notice to the undertaker written notice of its own estimate of a reasonable period for the duration within two days of receiving the undertaker’s estimate.</p> <p>If the duration of the works is exceeds the prescribed period, or is likely to exceed either the period stated in a previous estimate of duration or the period agreed or determined under section 74(2) to be a reasonable period, the undertaker shall give a notice in writing containing an estimate or a revised estimate of duration. This estimate is assumed to be agreed by the authority, unless it gives a written notice to the undertaker of its own estimate of a reasonable period for the duration within two days of receiving the undertaker’s estimate.</p>

### 11.3 Time Periods

An FPN should be given as soon as is reasonably practicable. It may not be given more than 91 calendar days after the commission of the offence, beginning with the day of its commission. It should be noted that all time periods, unless otherwise stated, are in working days.

The penalty is £120. The period for payment is 36 calendar days, beginning with the day on which the FPN is given. The street authority may extend this period at its discretion in any particular case.

A discounted amount of £80 will apply if payment is made within 29 calendar days, beginning with the day on which the FPN is given. If the last day of the discounted period does not fall on a working day, the discounted payment period is extended until the end of the next working day.

If the undertaker pays either the full penalty, or the discounted amount, within the required period, no further proceedings can be taken for that offence. Once an FPN has been given,

proceedings for that offence cannot commence until the end of the period for payment.

If the undertaker does not pay the penalty within the 36 calendar days then the street authority may bring proceedings in the Magistrates' Court for the original offence. A street authority should have sufficient time to collate its case and take action, within the six months deadline for bringing a case before the Magistrates' Court (section 127 of the Magistrates' Courts Act 1980) – even if the FPN was not given for some time after the offence was committed.

## **11.4 Guidance for the Street Authority**

### **11.4.1 Basic principles**

Street authorities are recommended to give FPNs where they have the most benefit. The street authority must act reasonably. It should apply the same due process for giving an FPN as it would in taking the undertaker to the Magistrates' Court.

Good communication between the street authority and the undertaker is essential for timely and accurate notices, and efficient co-ordination of works.

An agent may deal with FPNs on behalf of the street authority - provided that TMA powers for fixed penalty offences have been the subject to a Contracting Out Order, under the Deregulation and Contracting Out Act 1994. However, the authority remains responsible for ensuring that the powers under section 95A of NRSWA are used correctly and responsibly.

### **11.4.2 The Fixed Penalty Notice**

The fixed penalty notice FPN must be given in the form prescribed in the regulations and included in Appendix H, Table H2.

The fixed penalty notice has two parts:

- Part A includes information about the street authority and the offence.
- Part B includes information about payment of the penalty. It also includes a table listing the relevant offence codes, for use in Part A.

Guidance on completing the fixed penalty notice form:

The Street Authority may choose to incorporate its 4-digit Data Capture Code

*	<b>FIXED PENALTY NOTICE</b> <b>NEW ROADS AND STREET WORKS ACT 1991</b> (Section 95A and Schedules 4A and 4B)	<b>FIXED PENALTY NOTICE</b> Number: .....
(* Insert Street Authority name )		

**PART A**

Contact Tel No.	Works Ref No. * Street Authority No. * (*To be left blank where the offence relates to works in respect of which no notice has been given.)
-----------------	---

<b>TO:</b>	<b>DATE OF THIS NOTICE:</b> .....
	dd mm yy
<b>ADDRESS:</b> ←	Undertakers are asked to provide, where possible, an electronic address as well as the postal address. If the undertaker fails to provide a postal address then the fixed penalty notice should be served in accordance with the options set out in the regulations

**OFFENCE CODE:** (See Part B) (NB: Only one offence code per fixed penalty notice) .....

<b>LOCATION:</b> ←	Actual location of works
	Insert relevant offence code from Part B

**DATE OF OFFENCE:**

<b>DETAILS OF OFFENCE:</b>	This box needs to specify reasonable particulars of the circumstances alleged to constitute the offence and should be expanded if required
----------------------------	--

1. I am giving you this notice, in accordance with section 95A of, and Schedule 4B to, the New Roads and Street Works Act 1991, to offer you the opportunity of discharging any liability to conviction for this fixed penalty offence by payment of a penalty.

2. This means that no legal proceedings will be commenced for the offence if, subject to paragraph 3, the penalty of **£120** is paid (See Part B for instructions on methods of payment) within the period of **36** days beginning with the day on which this notice was given. (NB: The street authority may extend this period in any particular case if they consider it appropriate to do so (See paragraph 4(3) of Schedule 4B)).

3. Instead of paying the amount referred to in paragraph 2, liability to conviction for the offence may also be discharged if the discounted amount of **£80** is paid within the period of **29** days beginning with the day on which this notice was given. (NB: If the last day of this period does not fall on a working day, the period for payment of the discounted amount is extended until the end of the next working day (See Paragraph 5(3) of Schedule 4B)).

4. If the discounted amount is not paid within the period set out in paragraph 3, as extended where relevant, liability to conviction for the offence may only be discharged thereafter by payment of the penalty of **£120** within the period set out in paragraph 2, as extended where considered appropriate. If you then fail to pay the penalty within that period, legal proceedings for the offence may be commenced against you.

5. Any representations that you wish to make in relation to this notice may be addressed to

<b>NAME OF AUTHORISED OFFICER (in block capitals):</b>	at
.....	identifying the
	.....
<b>DATE:</b>	.....

These should be different officers. See section 10.6 for a fuller discussion of the Representations process.

Representations in writing should be made to this officer. This may be a named individual or department, but the authority should provide full contact details.

<b>PART B</b>		This must match the number given in Part A
*	<b><u>INSTRUCTIONS ON METHODS OF PAYMENT</u></b>	<b>FIXED PENALTY NOTICE</b> Number: ..... ...
(* Insert Street Authority name)		
<b>ELECTRONICALLY</b> – by the Bankers Automated Clearing Services (BACS). Payment should be made to _____, Sort Code _____, Account Number _____. Payment must be supported by the timely submission of a list of the fixed penalty notice numbers covered by the payment and the amount being paid in relation to each number.		
<b>“ON LINE”</b> - please visit our web site at _____		← Insert 'N/A' if this method of payment is not available
<b>BY POST</b> - by making your cheque payable to _____ and sending it to _____. Payment must be accompanied by a list of the fixed penalty notice numbers covered by the payment and the amount being paid in relation to each number. A receipt will be sent on request.		
<b>IN PERSON</b> – to _____ at _____ between _____ am and _____ pm on any day on which the office is open for business. Any cheque should be made payable to _____. Payment may be made by debit or credit card if the card is one that is accepted by the Street Authority in accordance with its standard procedures. Payment must be accompanied by a list of the fixed penalty notice numbers covered by the payment and the amount being paid in relation to each number. A receipt will be provided on request.		
<b>BY TELEPHONE</b> – by contacting _____ at _____ on _____ between _____ am and _____ pm on any day on which the office is open for business. Payment may only be made by using a debit or credit card that is accepted by the Street Authority in accordance with its standard procedures. You must state the fixed penalty notice number of each notice in respect of which payment is being made and the amount being paid in relation to each number. A receipt will be sent on request.		
<b>OTHER METHOD/S</b> - * (* Insert details where applicable.)		

<b>OFFENCE CODES AND DESCRIPTION</b> (By reference to the New Roads and Street Works Act 1991)		
<b>COD E</b>	<b>OFFENCE</b>	<b>BRIEF DESCRIPTION</b>
<b>01</b>	An offence under s.54(5).	Failure to comply with duties under s.54 (advance notice of certain works, etc.).
<b>02</b>	An offence under s.55(5).	Beginning to execute works in contravention of s.55 (notice of starting date).
<b>03</b>	An offence under s.55(9).	Failure to give notice in accordance with s.55(8) (notice to be given on s.55 notice ceasing to have effect).
<b>04</b>	An offence under s. 57(4).	Failure to give notice in accordance with s.57 (notice of emergency works).
<b>05</b>	An offence under s.70(6) consisting of a failure to comply with subsection (3) or (4A).	Failure to comply with requirements to give notice of completion of reinstatement.
<b>06</b>	An offence created by regulations made under s.74(7B).	Failure to give a notice required by regulations under s.74 (charge for occupation of the highway where works unreasonably delayed).

### 11.4.3 Giving the Fixed Penalty Notice

FPNs can be processed more easily if they are given electronically. But other means of giving the fixed penalty notice are permitted.

If an undertaker wishes to receive FPNs by electronic means, it should tell the street authority which method (eg EToN, e-mail or fax) and provide details of the EToN web service URL or e-mail address or fax number to be used as appropriate. The EToN web service details should be provided in the ODD submission (see Technical Specification for EToN). Where an address for service using a particular method for transmitting an electronic communication has been given for receipt of FPNs and the street authority has not been notified that the address is withdrawn then an FPN must be given by sending to that electronic address.

The street authority has to meet the three conditions set out in regulation 5(3) of the Street Works (Fixed Penalty) (Wales) Regulations 2008 when giving an electronic FPN:

*'the fixed penalty notice shall be -*

- (i) capable of being accessed by the person to whom it is being sent;*
- (ii) legible in all material respects; and*
- (iii) in a form sufficiently permanent to be used for subsequent reference,*

*and for this purpose "legible in all material respects" means that the information contained in the fixed penalty notice is available to that person to no lesser extent than it would be if given by means of a fixed penalty notice in printed form."*

An electronic FPN is deemed to be given on the day and at the time the transmitting apparatus records as being the day and time of satisfactory completion of the transmission, unless the contrary is proved. This is subject to section 98(2) of NRSWA.

In all other circumstances, including system failures or if the street authority has tried and failed to use electronic means the fixed penalty may be given by alternative methods such as:

- delivering it to the person to whom it is to be given
- leaving it at his proper address
- sending it by first class post to him at that address or
- by any other agreed means.

For service of a fixed penalty notice in these circumstances, the "proper address" is the postal address given by the undertaker to the street authority for those purposes, or, the registered or principal office of a corporation, or the last known address of such person.

Section 98(2) of NRSWA provides that a notice given after 16:30 on a working day is deemed to have been given on the next working day.

The Technical Specification for EToN includes a non-mandatory message type for sending an FPN using EToN.

### 11.4.4 Withdrawing a fixed penalty notice

If a street authority considers that a fixed penalty notice FPN ought not to have been given, they may give a notice withdrawing the fixed penalty notice. If a notice withdrawing the fixed penalty notice FPN is given, the authority shall repay any amount that has been paid by way of penalty, and proceedings shall not be commenced or continued for that offence.

Guidance on completing the fixed penalty notice withdrawal form: is given below.

<p style="text-align: center;">*</p> <p><i>(* Insert Street Authority name)</i></p>	<p><b>NOTICE WITHDRAWING FIXED PENALTY NOTICE</b></p> <p><b>NEW ROADS AND STREET WORKS ACT 1991</b></p> <p>(Section 95A and Schedules 4A and 4B)</p>	<div style="border: 1px solid black; padding: 2px; width: fit-content; margin-bottom: 5px;">             This number must match that given on the FPN form           </div> <p><b>FIXED PENALTY NOTICE</b></p> <p>Number: .....</p>
---	--	---

<p><b>TAKE NOTICE</b> that the fixed penalty notice numbered as above is hereby <b>WITHDRAWN</b>.</p>
<p><b>NAME OF AUTHORISED OFFICER</b> <i>(in block capitals)</i></p> <p>.....</p>
<p><b>DATE</b></p> <p>.....</p>

### 11.5 Guidance for Undertakers

#### 11.5.1 Basic Principles

An FPN provides the opportunity for an undertaker to discharge any liability to conviction for certain offences by payment of a fixed penalty. An FPN will be given to the undertaker promoting the works and not to any contractor carrying them out. Noticing and other procedures under Part 3 can be carried out by an agent, but the undertaker should inform the street authority if it wishes FPNs to be handled by the agent as well. The undertaker remains responsible for managing the process of complying with its statutory duties and obligations under Part 3.

#### 11.5.2 Payment of the fixed penalty notice

The undertaker should set up payment facilities, give contact details, and agree methods of payment with street authorities' finance departments.

The street authority should indicate all available methods of payment in part B of the FPN form. The main options are:

- electronic payment using the Bankers Automated Clearing Services ("BACS")
- on-line, via the street authority web site (if available)
- by post
- in person or
- by telephone.

Payment must either be accompanied by a list of the relevant FPN numbers and the

amount being paid against each (discounted or full) or in the case of BACS payment such a list should be provided separately. This applies, whichever form of payment is used

Remittance advice should be processed quickly and accurately.

Electronic payment methods are strongly encouraged. However, it is an undertaker's responsibility to ensure its preferred payment method is accepted and the hours within which it can do so

## **11.6 Representations**

It is strongly recommended that representations should be made as soon as is reasonably practicable.

Before making an official representation, the undertaker is advised to try to resolve the issue informally by contact with the officer who gave the FPN. If this fails then the undertaker should make a formal written representation to the officer, individual or department, specified on the FPN as responsible for considering representations.

Street authorities should have a nominated official to consider all FPN representations and should ensure that a fair and open system is in place to consider them.

The street authority may extend the full payment period while representations are being considered. It is **NOT** able to extend the discounted payment period.

## **11.7 Application of Money by the Street Authority**

The street authority may deduct from the fixed penalties received under Schedule 4B to NRSWA, the reasonable costs of operating the scheme. The street authority shall apply the net proceeds to develop policies to promote and encourage safe, integrated, efficient and economic transport facilities and services, to, from and within its area.

Street authorities need to be able to demonstrate that the costs of running the FPN scheme are reasonable, and that the net proceeds, after deducting those costs, are being correctly applied. Accounts are prepared annually. Although separate accounts are not required for an FPN scheme, there should be an audit trail of income and expenditure.

The FPN scheme is **NOT** intended as an additional source of income for street authorities. The street authority should therefore not expect any net proceeds.



## 12. RELATED MATTERS

### 12.1 Road Closures and Traffic Restrictions

Provisions governing temporary road closures and traffic restrictions for street works are found in Sections 14-16 of the Road Traffic Regulation Act 1984, as amended by the Road Traffic (Temporary Restrictions) Act 1991 and Regulations made under the 1984 Act<sup>9</sup>.

There are two procedures:

- (a) Where urgent action is needed – the traffic authority may issue a **'temporary notice'** imposing a short-term closure or restriction. Prior notice is not necessary.

The notice is limited to 21 days if there is a danger to the public or risk of serious damage to the road, independent of street works; a leaking gas main, for example. It can be extended by one further notice.

The notice is limited to five days if there is no risk of danger or damage.

- (b) In less urgent cases – the traffic authority may make a **'temporary order'**, which may remain in force for up to 18 months. This is limited to six months for footpaths, bridleways, cycle tracks and byways, open to all traffic.

A temporary notice and a temporary order may provide that restrictions have effect only when traffic signs are lawfully in place. This will help limit traffic disruption where street works progress along a length of road.

In extraordinary circumstances, the Road Traffic Act 1991 section 49(4A), allows the police to suspend designated street parking places temporarily to prevent or mitigate traffic disruption, or danger to traffic. This could prove useful to undertakers carrying out emergency works.

#### 12.1.1 Procedure

##### Temporary notices

This procedure will only apply to immediate works.

The undertaker will inform the traffic authority as soon as practicable if a closure or traffic restriction is needed. The authority will consult with the police and all relevant parties, and confirm, as soon as possible, whether or not a notice will be made.

The traffic authority must state in the notice:

- the reason for issue
- its effect
- alternative routes (where applicable) and,
- the date and duration of the notice.

---

<sup>9</sup> The Road Traffic (Temporary Restrictions) Procedure Regulations 1992 SI 1992/1215

The traffic authority must also notify the emergency services and any other traffic authority with roads that may be affected. This should be done on, or before, the day the notice is issued.

### **Temporary orders**

The traffic authority must publish notice of intention to make a temporary order at least seven days in advance. If the order is expected to last for more than 18 months because works are to be executed on or near the road, the proposal must be advertised at least 21 days in advance and published in two local newspapers. Such orders must be revoked as soon as the works are completed.

The traffic authority must also notify the emergency services and any other traffic authority with roads that may be affected. This should be done on, or before, the day the order is issued. These bodies should be consulted, as well as notified, if the closures are expected to last for more than 18 months.

A temporary traffic order is generally needed for planned street works (except where the order follows a closure notice). If a closure order is needed, the undertaker should notify the traffic authority at least three months in advance. This will allow the authority time to consult, and to obtain approvals and advertise the order. Works that required a temporary traffic order are automatically classed as major works and require at least three months notice and the procedures set out in chapter 8 will apply.

The undertaker must submit with the application for an order all the information needed to justify the need for a road closure.

### **Continuation of closures and restrictions**

A five-day temporary traffic closure or restriction notice cannot be extended. A 21-day temporary notice can be extended by one further notice giving up to 21 days more. Both five-day and 21-day notices may be followed immediately by a temporary order. This may be made without the seven days prior notice normally needed for such orders.

If the original estimate of the duration of the works changes, a statutory Revised Duration Estimate notice, under section 74 of NRSWA, will be necessary.

There will be cases where works will unavoidably overrun the temporary notice period.

Where this is apparent from the beginning, undertakers must inform the traffic authority. The authority will take the necessary follow-up action, without delay, to enable the works to continue uninterrupted.

If the overrun becomes apparent only after works have started, the undertaker should immediately inform the authority that either a further notice or an order will be required. This may be needed before a statutory Revised Duration Estimate notice is served.

It might not be possible to make a follow-up order before a five-day notice expires. Works may have to be suspended, and the site temporarily restored to traffic, until the correct procedures have been followed. The traffic authority will try to minimise both, the number of cases where this happens, and, where it is unavoidable, the period of suspension involved. This problem is unlikely to arise in the case of a 21-day temporary order.

Subject to the time limit referred for 'Temporary Orders', see above, a closure or restriction imposed by a temporary order may be continued by a further order. If this is required, the undertaker should notify the traffic authority immediately, giving, wherever possible, at least one month's notice.

### **12.1.2 Policy guidance**

When a notice or order has been made, the undertaker must comply with the requirements of the traffic authority and the police for the closure of the road.

Undertakers are required, by section 66 of NRSWA, to carry on and complete their street works "with all such despatch as is reasonably practicable". Street authorities may require unreasonably lengthy obstructions to be mitigated or discontinued. There is a presumption that closures or restrictions will remain in force only for as long as is necessary to fulfil their original purpose.

Highway authorities are under a statutory obligation to maintain a public right of passage and they also are expected to carry out works with due despatch.

### **12.1.3 Charges**

Section 76 of NRSWA allows for traffic authorities to recover the costs of issuing temporary notices or making temporary traffic regulation orders (TRO). Upon application for a TRO, highway authorities should provide utilities with the estimated cost. Invoices should be itemised as follows:

- (a) Cost of order
- (b) Advertising in local papers
- (c) Administration.

## **12.2 Maintenance of Undertakers' Apparatus**

Undertakers have a duty, under section 81 of NRSWA, to maintain apparatus in the street to the reasonable satisfaction of the street authority, having regard for the safety and convenience of traffic, the structure of the street, and, integrity of apparatus in it. Bridge, sewer and transport authorities also have an interest, so far as any land, structure or apparatus they own is concerned.

Most undertakers have statutory obligations to maintain their networks - quite apart from which, they must maintain systems in efficient working order to properly discharge their safety and service obligations to their customers.

Thus authorities and undertakers have a shared interest in the proper maintenance of apparatus in the street.

As with reinstatements, it is important that the street authority reports any apparatus in an unsatisfactory condition quickly and accurately and includes the level of severity of the problem. The owner must respond and carry out any necessary remedial works within the reasonable timescales agreed with the street authority.

### **12.2.1 Practical considerations**

Although NRSWA gives street authorities certain default powers to inspect and carry out emergency works, neither street authorities nor undertakers expect the need to arise. However, should it happen, then (without impeding any immediate emergency action) the matter will be referred to the agreed dispute resolution procedure.

The street authority must immediately notify the undertaker if surface apparatus is found to be defective or the cause of significant surface irregularity, or where an unexplained subsidence or other disturbance of the road surface occurs. This should be done in accordance with the protocols set out in the Technical Specification for EToN, or a locally agreed protocol. The authority may arrange a site meeting by agreement with the undertaker. If an undertaker accepts responsibility for previously un-attributable street works, it must issue relevant notices using its own works reference, rather than that generated by the street authority.

If the problem is agreed to be the undertaker's responsibility, it must take immediate action to investigate and initiate any necessary remedial works, in accordance with the following principles:

- (a) Dangerous defects – requires an immediate response
- (b) Non-Dangerous – requires a response within the timescales agreed with the street authority

### **Dangerous**

Apparatus that requires an immediate response or remedial works or to avoid injury or damage to persons or property shall be considered dangerously defective.

Examples include:

- missing covers and/ or frames
- sunken or raised covers and/ or frames (generally greater than 25mm depth/trip).

Notwithstanding the above, the street authority may execute any emergency works needed in consequence of the undertaker failing to maintain his apparatus.

### **Non-Dangerous – requires a response within the timescales agreed with the street authority:**

Non-Dangerous defective apparatus is apparatus which requires attention to comply with specifications or remove nuisance; or has the potential to escalate to "Dangerous" in the near future.

Examples may include:

- cracked covers and/or frames
- sunken or raised covers and/ or frames (generally less than 25mm depth/trip)
- rocking covers and/or frames
- worn/polished covers in carriageways and cycleways, on bends, or on the approaches to "Stop" lines; "Give-Way" lines; traffic lights; pedestrian crossing lights; zebra crossings; and, railway/tramway level crossings. These covers could also be Dangerous depending on the circumstances at the site.

Note: The decision on whether an occurrence is Dangerous or Non-Dangerous will, by necessity, have to be made on site. It should not be challenged unreasonably. Hence, it is important that the classifications are strictly applied.

An undertaker may reduce the time for response, to meet operational needs for example, but shall not exceed the recommended timescales.

It is important that only the responsible undertaker, or a specialist contractor working on its behalf, investigates suspected damaged or defective apparatus, excluding manhole covers and frames. Street authorities will carry out investigations or remedial works (using appropriately trained and experienced persons) only in an emergency, or where the undertaker is unable or unwilling to use their own operatives or specialist contractor.

Notification will be made using the protocols set out in the Technical Specification for EToN.

If the street authority has opened the street or exposed the undertaker's' apparatus in an emergency, or in the circumstances described above, the undertaker will assist the authority by:

- jointly inspecting the problem to determine necessary remedial works or
- confirming approval for the authority to proceed.

The authority and the undertaker should agree the time within which it is reasonable for the undertaker to assist before the authority commences remedial works. The reasonably incurred costs may be charged to the undertaker.

### **12.3 Working near Rail Tracks and Tramways**

Please see Appendix C.

Works promoters planning works near to, adjacent or across the lines of street-running tramways must contact the transport authority responsible for that tramway as early in their planning cycle as possible. The promoter's requirements can be incorporated into the contract documents.

### **12.4 Vehicle Parking at Street and Road Works**

**This is not safety advice. The *Code of Practice on Safety at Street Works and Road Works* should always be consulted.**

#### **12.4.1 Vehicle within works site**

A works vehicle may be parked in a works site provided that it is necessary for carrying out those works. Basic site layouts are shown in the *Code of Practice on Safety at Street Works and Road Works*. A vehicle entirely within the coned-off area of the site may require a larger coned-off area than would otherwise be the case.

#### **12.4.2 Vehicle outside works site**

A vehicle may be parked outside a works site provided that it obeys the parking rules that apply to any other vehicle in that street. Outside the works site, the vehicle has no special status and no exemption from parking enforcement.

#### **12.4.3 Implications**

When assessing the impact of works (see 12.7 and Appendix G) the parking of works vehicles must be taken into account.

This is a particular problem for works which, but for the presence of a works vehicle, would take place entirely within the footway. If a vehicle is parked adjacent to the

works, in a place which vehicles could not normally use, then it must be part of the works site. It must be signed and guarded appropriately. The works are then not wholly confined to the footway but encroach onto the carriageway. Noticing must reflect this.

#### **12.4.4 Parking restrictions**

The Traffic Regulation Order imposing parking restrictions on a particular street should already contain an exemption allowing works to take place in a parking bay. Undertakers should check whether any further dispensation is required well before the works are due to start.

### **12.5 Storing Materials**

Works promoters and street authorities should take care to place materials so that they do not cause an obstruction to road users. This is especially important if the materials are stored away from the works site but still within the highway boundaries. Storage must be noticed if it is in a different street from the works site.

### **12.6 Apparatus belonging to others**

There may be other apparatus where works are planned and under section 69, those carrying out works must ensure that the owners of that apparatus are able to monitor the works and that requirements to take reasonable steps to protect the apparatus are followed. Failure to do so is a criminal offence.

### **12.7 Assessing the Impact of Works**

This section explains the 'Disruption Effect Score' and describes the approach to assessing the impact of activities on general traffic, buses and pedestrians.

All activities in the highway have a disruptive effect on traffic. The disruption effect score is based on a measure of congestion resulting from a restriction on the highway. It is derived from a number of simple factors that can be easily established for any given activity.

#### **12.7.1 Disruption effect score**

The disruption effect score is a simple numeric indicator of the disruption likely to arise from a given activity. The use of the disruption effect score is described in Appendix G.

The nature of traffic flow and the relationship between flow, capacity, and delay are highly complex and subject to a variety of factors. However three specific factors can be used to ascertain congestion: the total width of a road; the extent to which the activities reduce the available width; and the traffic flow.

#### **12.7.2 Impact assessments**

Assessment of the impact of activities on general traffic, buses and pedestrians may be included, together with the disruption effect score, in the information included in a notice. The assessment is a broad indicator of the likely disruptive effect of the proposed activity. Details on the derivation and use of the impact assessments are included in Appendix G (G4).

#### **12.7.3 Use of impact assessments**

The impact assessment can be used within the co-ordination process to prioritise

activities according to their potential for causing disruption. The assessment can also be used to provide public information on the disruptive effects of activities.

## **12.8 Environmental Issues**

Works promoters are strongly advised to liaise with the authority's arboriculture consultants and other environmental officials when drawing up proposals. This should ensure that wherever possible, and at reasonable cost, their requirements can be met.

An undertaker considering burying plant and apparatus that is currently above ground, should contact any other utility with similar apparatus in that street to see whether it wishes to share the underground facility.

## **13. DISPUTE RESOLUTION**

### **13.1 Introduction**

This Code is intended to provide sufficiently detailed guidance to enable agreement on its operation and implementation to be reached at local level. Street authorities and undertakers should always try to resolve disputes without having to refer them to a formal appeals procedure. This could, for instance, be achieved by referring the issue to management.

### **13.2 Appeals Procedure**

Part 3 of NRSWA, as amended by the TMA, provides for procedures to be set up to resolve disputes in certain areas. The procedures below apply to the resolution of disputes under the following sections:

- NRSWA section 56A - "Power to give directions as to placing of apparatus". An undertaker may appeal against a direction, which it considers unreasonable
- NRSWA section 58 - "Restrictions on works following substantial road works". An undertaker may appeal where it considers that an authority has unreasonably refused its consent to the undertaker carrying out works on a street where a restriction is in place
- NRSWA section 58A - "Restrictions on works following substantial street works". An undertaker may appeal where it considers that an authority has unreasonably refused its consent to the undertaker carrying out works on a street where a restriction is in place.

### **13.3 Dispute Review**

If agreement cannot be reached locally on any matter arising under any part of this Code, the dispute should be referred for review on the following basis:

#### **13.3.1 Straightforward issues**

Where the two parties consider that the issues are relatively straightforward, the matter should be referred to impartial members of a regional HAUC. Impartial members are those not representing parties directly involved in the dispute. The review should take place within five working days of referral. It is recommended both parties accept the result as binding.

#### **13.3.2 Complex issues**

Where the parties consider that the issues are particularly complex, they should apply to HAUC for a review panel of four persons (two utilities and two street authorities). One of the four persons will be appointed as Chair of the panel by the HAUC joint chairs.

Each party must make available all financial, technical and other information relevant to the matter in dispute.

The review would normally take place within ten working days from the date of referral to HAUC. It is recommended each party accept the advice given by the review panel as binding.



## **13.4 Adjudication**

If agreement cannot be reached by either of the procedures in 13.3 above, the dispute should be referred to independent adjudication. The decision of the adjudicator is deemed to be final. The costs of adjudication will be borne equally unless the adjudicator considers that one party has presented a frivolous case, in which case costs may be awarded against them. Where the adjudication route is to be followed, the parties should apply to the joint chairs of HAUC, who will select and appoint the independent adjudicator from suitable recognised professional bodies.

## **13.5 Arbitration**

Disputes relating to matters covered by the following sections of NRSWA may be settled by arbitration, as provided for in section 99:

- section 58 (7A) - restriction on works following substantial road works
- section 58A - restriction on works following substantial street works
- section 61 (6) - consent to placing apparatus in protected streets
- section 62 (5) - directions relating to protected streets
- section 74 (2) - charges for occupation of the highway where works are unreasonably prolonged
- section 84 (3) - apparatus affected by major works
- section 96 (3) - recovery of costs or expenses.

**If an important point of principle, or a particularly expensive scheme, is involved, either party may refer the matter to arbitration, as if it were a matter to be settled by arbitration under section 99 of the act.**

# APPENDICES

## Where to find information in Appendices in First Edition

Appendix Title	First Edition Location	New Appendix Title	2008 Edition Location
Definitions	Appendix A	Glossary	Appendix A (Volume 1 of the Code of Practice)
Timeline Diagrams & Flow Charts	Appendix B	N/A	Technical Specification for EToN
Sample Form for Section 58 Notice	Appendix C	N/A	Technical Specification for EToN
Paper Transfer of Notices	N/A	N/A	Technical Specification for EToN
Electronic Transfer of Notices	Appendix E	N/A	Technical Specification for EToN
Street Works at or near Level Crossings	N/A	Works at or near level crossings	Appendix C
Street Works near Highway Structures	Section 5.7	Works near highway structures	Appendix D

## Appendix A GLOSSARY

Section and paragraph references (e.g.2.2. and 2.2.1) are references to the Code of Practice

Term	Explanation
Above ground works	Any works (not being overhead works) which do not involve the breaking up or opening of the street or tunnelling or boring under it
Additional street data ("ASD")	As it says in section 4.3. Additional Street Data ("ASD") refers to other information about streets held on the NSG concessionaire's website alongside the NSG
adjudication	Section 13.4
Apparatus	As defined in section 105(1) of NRSWA "apparatus includes any structure for the lodging therein of apparatus or for gaining access to apparatus"
appeal	Section 13.2
Arbitration	As defined in section 99 of NRSWA, "any matter which under this Part is to be settled by arbitration shall be referred to a single arbitrator appointed by agreement between the parties concerned or, in default of agreement, by the President of the Institution of Civil Engineers"
Bank holiday	As defined in section 98(3) of NRSWA, "bank holiday means a day which is a bank holiday under the Banking and Financial Dealings Act 1971 in the locality in which the street in question is situated"
Bar hole	As stated in 7.3.5., a bar hole is used to detect and monitor gas leaks.
Breaking up (the street)	Any disturbance to the surface of the street (other than opening the street)
Bridge	As it says in section 88(1)(a) of NRSWA, "references to a bridge include so much of any street as gives access to the bridge and any embankment, retaining wall or other work or substance supporting or protecting that part of the street"
Bridge authority	As defined in section 88(1)(b) of NRSWA, "bridge authority means the authority, body or person in whom a bridge is vested"
Bridleway	As defined in section 329 of the HA 1980, "bridleway means a highway over which the public have the following, but no other, rights of way, that is to say, a right of way on foot and a right of way on horseback or leading a horse, with or without a right to drive animals of any description along the highway"
BS7666	British Standard number 7666 relating to gazetteers
Carriageway	As defined in section 329 of HA 1980, "carriageway means a way constituting or comprised in a highway, being a way (other than a cycle track) over which the public have a right of way for the passage of vehicles"
Central register	As stated in 3.3, a central register is a register covering two or more street authority areas that is maintained by one single authority, the 'register authority'. For example, a central register could include all authorities in a metropolitan area
Contravention	As defined in section 329 of HA 1980, "contravention in relation to a condition, restriction or requirement, includes failure to comply with that condition, restriction or requirement, and "contravene" is to be construed accordingly"
Council	As defined in section 329 of HA 1980, "council means a county council, or a local authority"
Critical gyratory or	A gyratory or roundabout system where, in the absence of street works or

roundabout system	works for road purposes, no less than 5 per cent of peak hour vehicles on average are delayed by more than 20 seconds
Critical signalised junction	A traffic signal junction at which, in the absence of street works or works for road purposes and at times when the exit is not blocked, no less than 5 per cent of peak hour vehicles on average fail to clear the junction on the first green signal
Culvert	A structure in the form of a large pipe or pipes, box or enclosed channel generally used for conveying water under a road
Cycle track	As defined in section 329 of the HA 1980, "cycle track means a way constituting or comprised in a highway, being a way over which the public have the following, but not other, rights of way, that is to say, a right of way on pedal cycles with or without a right of way on foot"
day	a working day, unless explicitly stated otherwise
DfT	Department for Transport
Disability	As defined in section 105(5) of NRSWA, "Section 28 of the Chronically Sick and Disabled Persons Act 1970 (power to define "disability" and other expressions) applies in relation to the provisions of this Part as to the provisions of that Act"
Distribution Network Operator (DNO)	Operator of an electricity distribution network
e-government	The Government objective to deliver efficiency savings while improving the delivery of public services by joining up electronic government services around the needs of customers
Emergency works	As defined in section 52 of NRSWA, "emergency works means works whose execution at the time when they are executed is required in order to put an end to, or to prevent the occurrence of, circumstances then existing or imminent (or which the person responsible for the works believes on reasonable grounds to be existing or imminent) which are likely to cause danger to persons or property"
Excavation	"Breaking up" (as defined above)
Extensible Markup Language (XML)	A self-describing data format providing (amongst other things) a method of transferring data between systems. Note that the UK Government eGIF standard mandates XML for this purpose.
File transfer protocol (FTP)	A method of transferring data between computers defined by RFC959 (RFCs - Request for Comments) are the standard documents that define the operation of the internet)
Fixed Penalty Notice	As defined in schedule 4B to NRSWA, "fixed penalty notice means a notice offering a person the opportunity of discharging any liability to conviction for a fixed penalty offence by payment of a penalty"
Footpath	As defined in section 329 of the HA 1980, "footpath means a highway over which the public have a right of way on foot only, not being a footway"
Footway	As defined in section 329 of the HA 1980, "footway means a way comprised in a highway which also comprises a carriageway, being a way over which the public have a right of way on foot only"
Frontager	A person or body occupying premises abutting the street
Geographical information system (GIS)	A computer system for capturing, storing, checking, integrating, manipulating, analysing and displaying data related to positions on the Earth's surface
HA 1980	The Highways Act 1980
HAUC(UK)	The Highway Authorities and Utilities Committee for the UK
Welsh HAUC	The Highway Authorities and Utilities Committee For Wales
Heavy commercial vehicle	As defined in section 138 of the Road Traffic Regulation Act 1984, "heavy commercial vehicle means any goods vehicle which has an operating weight exceeding 7.5 tonnes".

Highway	As defined in section 328 of the HA 1980, "highway means the whole or part of a highway other than a ferry or waterway"
Highway authority	As defined in sections 1 and 329 of the HA
Highway works	"works for road purposes" or "major highway works"
Immediate works	As stated in section 7.5.5, immediate works are either emergency works as defined in section 52 of NRSWA or urgent works as defined in <i>The Street Works (Registers, Notices, Directions and Designations) (Wales) Regulations 2008</i>
In	As defined in section 105(1) of NRSWA, "in, in a context referring to works, apparatus or other property in a street or other place includes a reference to works, apparatus or other property under, over, along or upon it"
Land	As defined in section 329 of HA 1980, "land includes land covered by water and any interest or right in, over or under land"
Local authority	As defined in section 270(1) of the Local Government Act 1972(a)
Local highway authority	As defined in section 329 of HA 1980, "local highway authority means a highway authority other than the Minister"
Local planning authority	Local planning authority has the same meaning as in the Town and Country Planning Act 1990"
Local register	As stated in 3.3, a local register is a register that is maintained by a single street authority for their own geographic area and will include information on all streets other than those streets that are the responsibility of another street authority
Local street gazetteer	A subset of the NSG containing details of all streets in a local highway authority area, being a self-contained entity created and maintained by the local highway authority covering all streets in their geographic area regardless of maintenance responsibility
Maintainable highway	As defined in section 329 of HA 1980, a "highway maintainable at the public expense means a highway which by virtue of section 36 above or of any other enactment (whether contained in this Act or not) is a highway which for the purposes of this Act is a highway maintainable at the public expense"
Maintenance	As defined in section 329 of HA 1980, "maintenance includes repair, and "maintain" and "maintainable" are to be construed accordingly"
Major works	As stated in section 7.5.2, major works are street works which have been identified in an undertaker's annual operating programme, or if not identified in that programme, are normally planned or known about at least six months in advance of the date proposed for the works; or street works, other than immediate works, where (i) the street authority has indicated to the undertaker, or (ii) the undertaker considers, that an order under section 14 of the Road Traffic Regulation Act 1984 (temporary prohibition or restriction on roads) is required; or street works, other than immediate street works, which have a planned duration of 11 days or more".
Major bridge works	As defined in section 88(2) of NRSWA, "major bridge works means works for the replacement, reconstruction or substantial alteration of a bridge"
Major highway works	As defined in section 86(3) of NRSWA, "major highway works means works of any of the following descriptions executed by the highway authority in relation to a highway which consists of or includes a carriageway - (a) a reconstruction or widening of the highway; (b) works carried out in exercise of the powers conferred by section 64 of the Highways Act 1980 (dual carriageways and roundabouts); (c) substantial alteration of the level of the highway; (d) provision, alteration of the position or width, or substantial alteration in the level of a carriageway, footway or cycle track in the highway; (e) the construction or removal of a

	road hump within the meaning of section 90F of the Highways Act 1980; (f) works carried out in exercise of the powers conferred by section 184 of the Highways Act 1980 (vehicle crossings over footways and verges); (g) provision of a cattle-grid in the highway or works ancillary thereto; or (h) tunnelling or boring under the highway"
Major transport works	As defined in section 91(2) of NRSWA, "major transport works means substantial works required for the purposes of a transport undertaking and executed in property held or used for the purposes of the undertaking"
Minor works	As stated in section 7.5.4, minor works are those street works other than immediate works where the planned duration is 3 days or less.
National Land and Property Gazetteer (NLPG)	Gazetteer providing a national reference of land and property related data
Nationally consistent street gazetteer (NSG)	A database defined as "an index of streets and their geographical locations created and maintained by the local highway authorities" based on the BS7666 standard
Network management duty	As stated in Part 2 of TMA
Notice management system	As stated in section 3.1, notice management systems receive electronic street works notices and are used by street authorities to manage them together with other relevant information.
NRSWA	New Roads and Street Works Act 1991
NSG Concessionaire	The body appointed to manage the NSG on behalf of the local highway authorities
ODD	operational district data
Opening (the street)	Removing a lid or cover to a manhole, inspection chamber, meter box or other structure embedded in the street without any "breaking up" of the street
Ordnance Survey Grid	A spatial location based on the geospatially referenced national grid owned by the Ordnance Survey
OSGR	Ordnance Survey Grid Reference
Pedestrian Planning Order	This refers to an order made under section 249(2) or (2A) of the Town and Country Planning Act 1990(10)
Prescribed	As defined in section 104 of NRSWA, "prescribed means prescribed by the Welsh Ministers by regulations, which may (unless the context otherwise requires) make different provision for different cases"
Protected street	As stated in section 5.2.2, any street that serves a specific strategic major traffic need and therefore needs to be protected from unnecessary excavation and works and providing there is a reasonable alternative route in which undertakers can place the equipment that would otherwise lawfully have been placed in the protected street.
Provisional street	As stated in section 4.2.3. a provisional street is a street that does not yet have an entry in the NSG. Typically these will be newly created and/ or private streets
Public sewer	Public sewer has the same meaning as in the Water Industry Act 1991
Railway	As defined in section 105(1) of NRSWA, "railway includes a light railway other than one in the nature of a tramway"
Reasonable period	As defined in section 74(2), "a reasonable period means such period as is agreed by the authority and the undertaker to be reasonable or, in default of such agreement, is determined by arbitration to be reasonable, for completion of the works in question"
Reasonable times	As stated in section 3.6.1, reasonable times may be taken to mean normal

(10) 1990 c.8. [ ].

	office hours (08:00 to 16:30, Monday to Friday except Bank Holidays)
REC	Regional electricity company
Registerable	As stated in 7.3.4, registerable works are those which should be registered under s 53 of NRSWA, which includes some highway authority road works.
Reinstatement	As defined in section 105(1) of NRSWA, "reinstatement includes making good"
Relevant authority	As defined in section 49(6) of NRSWA, "references in this Part to the relevant authorities in relation to any works in a street are to the street authority and also (a) where the works include the breaking up or opening of a public sewer in the street, the sewer authority; (b) where the street is carried or crossed by a bridge vested in a transport authority, or crosses or is crossed by any other property held or used for the purposes of a transport authority, that authority; and (c) where in any other case the street is carried or crossed by a bridge, the bridge authority"
Remedial work	As stated in section 7.6. remedial works are those required to put right defects identified in accordance with the provisions of the Welsh Assembly Government's Code of Practice for Inspections and regulations (2 <sup>nd</sup> October 2006)
Road	"highway"
Road category	This means one of the road categories specified in paragraph 1.3.1 of Chapter S.1 of the code of practice entitled "The Specification for the Reinstatement of Openings in Highways" made on 7 <sup>th</sup> November 2006 and coming into force on 24 <sup>th</sup> January 2007, as revised or re-issued from time to time
Road works	Works for road purposes
Schema	(XML) Schemas express shared vocabularies and allow machines to carry out rules made by people. They provide means for defining the structure, content and semantics of XML documents.
Sewer	Sewer as defined in the Water Industry Act 1991 " includes all sewers and drains (not being drains within the meaning given by this subsection) which are used for the drainage of buildings and yards appurtenant to buildings".
Sewer authority	As defined in section 89(1)(b) of NRSWA, "sewer authority, in relation to a public sewer, means the sewerage undertaker within the meaning of that Act in whom the sewer is vested"
Special Engineering Difficulties (SED)	As stated in 5.3.1, by virtue of section 63 of NRSWA, the term special engineering difficulties relates to streets or, more commonly, parts of streets associated with structures, or streets or extraordinary construction where street works must be carefully planned and executed in order to avoid damage to, or failure of, the street itself or the associated structure with attendant danger to person or property.
Standard works	As stated in 7.5.3. standard works are those street works, other than immediate works, that have a planned duration of between 4 and 10 days inclusive
Statutory right	As defined in section 105(1) of NRSWA, "statutory right means a right (whether expressed as a right, a power or otherwise) conferred by an enactment (whenever passed or made), other than a right exercisable by virtue of a street works licence"
Street	As defined in section 48(1) of NRSWA, "street means the whole or any part of any of the following, irrespective of whether it is a thoroughfare (a) any highway, road, lane, footway, alley or passage; (b) any square or court; (c) any land laid out as a way whether it is for the time being formed as a way or not"

Street authority	As defined in section 49(1) of NRSWA, "the street authority in relation to a street means, subject to the following provisions (a) if the street is a maintainable highway, the highway authority, and (b) if the street is not a maintainable highway, the street managers"
Street managers	As defined in section 49(4) of NRSWA, "the expression "street managers", used in relation to a street which is not a maintainable highway, means the authority, body or person liable to the public to maintain or repair the street or, if there is none, any authority, body or person having the management or control of the street"
Street works	As defined in section 48(3) of NRSWA, "street works means works of any of the following kinds (other than works for road purposes) executed in a street in pursuance of a statutory right or a street works licence: (a) placing apparatus; or (b) inspecting, maintaining, adjusting, repairing, altering or renewing apparatus, changing the position of apparatus or removing it, or works required for or incidental to any such works (including, in particular, breaking up or opening the street, or any sewer, drain or tunnel under it, or tunnelling or boring under the street"
Street works licence	As stated in section 50(1) of NRSWA, "the street authority may grant a licence (a "street works licence") permitting a person (a) to place, or to retain, apparatus in the street, and (b) thereafter to inspect, maintain, adjust, repair, alter or renew the apparatus, change its position or remove it, and to execute for those purposes any works required for or incidental to such works (including, in particular, breaking up or opening the street, or any sewer, drain or tunnel under it, or tunnelling or boring under the street)
TMA	The Traffic Management Act 2004
Traffic	As defined in section 105(1) of NRSWA, "traffic includes pedestrians and animals"
Traffic authority	As defined in section 121A of the Road Traffic Regulation Act 1984: "(1)(a)The (Welsh Ministers are) the traffic authority for every highway in (Wales) for which (they are) the highway authority within the meaning of the Highways Act 1980 (2) In England and Wales outside Greater London, the council of the county or metropolitan district are the traffic authority for all roads in the county or, as the case may be, the district for which the (Welsh Ministers are) not the traffic authority.
Traffic control	Any of the five methods of controlling traffic detailed in the Code of Practice "Safety at Street Works and Road Works"
Traffic flow	The number of vehicles using the particular street at specified times of the day and year, measured in accordance with DfT guidelines
Traffic order	This means an order made under section 1, 6 or 9 of the Road Traffic Regulation Act 1984
Traffic sensitive street	This means a street designated by a street authority as traffic sensitive pursuant to section 64 of NRSWA and in a case where a limited designation is made pursuant to section 64(3) any reference to works in a traffic sensitive street shall be construed as a reference to works to be executed at the times and dates specified in such designation
Traffic sign	As defined in section 105(1) of NRSWA, "traffic sign has the same meaning as in the Road Traffic Regulation Act 1984"
Tramway	As defined in section 105(1) of NRSWA, "tramway means a system, mainly or exclusively for the carriage of passengers, using vehicles guided, or powered by energy transmitted, by rails or other fixed apparatus installed exclusively or mainly in a street"
Transport authority	As defined in section 91(1)(a) of NRSWA, "transport authority means the



	authority, body or person having the control or management of a transport undertaking"
Transport undertaking	As defined in section 91(1)(b) of NRSWA, "transport undertaking means a railway, tramway, dock, harbour, pier, canal or inland navigation undertaking of which the activities, or some of the activities, are carried on under statutory authority"
Transport Consortia (in Wales)	One of four authorities (North Wales, Mid Wales, South East Wales and South West Wales) made up of representatives from local authorities in the area, responsible for public transport in their area.
Transport Wales	The section of the Department for the Economy and Transport that manages the Trunk Road network in Wales.
Trunk road	As defined in section 329 of the HA 1980, "trunk road means a highway, or a proposed highway, which is a trunk road by virtue of section 10(1) or section 19 above or by virtue of an order or direction under section 10 above or under any other enactment"
Type 1 (or 2, or 3) gazetteer	As defined in the British Standard BS7666
Undertaker	As defined in section 48(4) of NRSWA, "undertaker in relation to street works means the person by whom the relevant statutory right is exercisable (in the capacity in which it is exercisable by him) or the licensee under the relevant street works licence, as the case may be"
Unique street reference number (USRN)	As defined in the British Standard BS7666
Urgent works	As stated in section 7.5.5, urgent works are (a) street works (not being emergency works) whose execution at the time they are executed is required (or which the person responsible for the works believes on reasonable grounds to be required) (i) to prevent or put an end to an unplanned interruption of any supply or service provided by the undertaker; (ii) to avoid substantial loss to the undertaker in relation to an existing service; or (iii) to reconnect supplies or services where the undertaker would be under a civil or criminal liability if the reconnection is delayed until after the expiration of the appropriate notice period; and (b) Includes works that cannot reasonably be severed from such works
Working day	As defined in section 98(2) of NRSWA, "for the purposes of this Part a working day means a day other than a Saturday, Sunday, Christmas Day, Good Friday or a bank holiday; and a notice given after 4.30 p.m. on a working day shall be treated as given on the next working day"
Works	Street works or works for road purposes
Works clear	As stated in section 8.2.7, a works clear notice is used following interim reinstatement
Works closed	As stated in section 8.2.8, a works closed notice is used following permanent reinstatement
Works for road purposes	As defined in section 86(2) of NRSWA, "works for road purposes means works of any of the following descriptions executed in relation to a highway: (a) works for the maintenance of the highway; (b) any works under powers conferred by Part V of the Highways Act 1980 (improvement); (c) the erection, maintenance, alteration or removal of traffic signs on or near the highway; or (d) the construction of a crossing for vehicles across a footway or grass verge or the strengthening or adaptation of a footway for use as a crossing for vehicles"
XML	Extensible Markup Language

Page Not Used.

## Appendix B Transitional Arrangements

### B.1 Introduction

This appendix sets out the arrangements for transition from the provisions of the 1992 Regulations to those of 2008 Regulations when they come into force. This incorporates amendments to the noticing, directions and designation provisions of NRSWA introduced by the Traffic Management Act 2004 and the associated new Regulations. These are:

- *The Street Works (Registers, Notices, Directions and Designations) (Wales) Regulations 2008 ('Notices Regulations 2008');*
- *The Street Works (Fixed Penalty) (Wales) Regulations 2008 (FPN Regulations 2008).*

The Commencement Order<sup>11</sup> sets out when the new requirements apply.

B.1.2 A new EToN system, based on XML web services, as set out in the technical specification for EToN, will be introduced when the Regulations come into force. This EToN program incorporates the requirements of the new regulations and will include some automatic error checking to ensure that notices comply with statutory and technical requirements before transmission. This will affect how highway authorities and statutory undertakers exchange information, but should not impact on the management of street works or the use and availability of works registers.

### B.2 Principle

B.2.1 The main principle of the transitional arrangements is that:

- works which **were noticed and started** under the 1992 Regulations (*The Street Works (Registers, Notices, Directions and Designations) Regulations 1992 SI 2985*), or subsequent amendments to these regulations, will need to follow the requirements of those regulations to interim reinstatement
- some works, **noticed but not started** under the 1992 Regulations, may also follow this principle in certain circumstances
- those works notified after the Notices Regulations 2008 comes into force on 1st April 2008 must follow the new regulations.

B.2.2 The new regime simplifies and changes definitions of classes of works and associated notice periods. In particular, the advance notice period for major works (section 54 notice) changes from a minimum of one month to a minimum of three months. While it is necessary to maintain a steady flow of new starts for major works, it is equally important to minimise the time that local authorities and utility companies have to operate both the new and old regime to exchange data.

### B.3 Notices of planned works (section 54 and section 55)

B.3.1 It is anticipated that the greatest difficulties will be caused by works that are currently categorised as major projects or standard works under the 1992 regulations, but as major works under the 2008 Regulations. The section 54 notice period for such works increases from one month to three months, and such works may take several months to complete, for example a mains replacement. Undertakers may wish to review their programme of works to consider whether to provide notice earlier than

---

<sup>11</sup> The Traffic Management Act 2004 (Commencement No 2 and Transitional Provisions) (Wales) Order 2007  
<http://www.opsi.gov.uk/legislation/wales/wsi2007/20073285e.htm>

usual for those works schedule to take place shortly after 1<sup>st</sup> April 2008, when the 2008 Regulations come into force. This will reduce the risk of a two-month dip in the start of major works. Changes to the section 55 noticing periods for minor and standard works are less significant and less likely to impact on long-term planning by either an undertaker or local highway authority.

**B.3.2 The general principles of the transitional arrangements are:**

- if the works have begun before 1<sup>st</sup> April 2008, then the existing requirements, under the 1992 Regulations, apply until either a works clear notice for interim reinstatement or works closed notice for permanent reinstatement is given
- If advance notice of works (section 54 notices) has been given before 1<sup>st</sup> April 2008 with a proposed start date before 1<sup>st</sup> April, but has not started by 22<sup>nd</sup> April 2008, then the section 54 notice ceases to have effect. If it is proposed to carry out the works a fresh section 54 notice should be given
- if the works have been noticed before 1<sup>st</sup> April, but have not started, and have a proposed start date after 1<sup>st</sup> April and before 1<sup>st</sup> July, then the 1992 Regulations apply to all notices related to that phase of works - e.g. one month notice period for section 54 and seven-day notice for section 55. Subsequent phases, which have not been noticed, would need to follow the requirements of the Notices Regulation 2008
- if the works have been noticed before 1<sup>st</sup> April, but not started, and the start date is more than three months after that date (ie 1st July or later), then the notice served under the 1992 Regulations ceases to have effect. A fresh notice should be given that follows the requirements of the 2008 Regulations.

There is no change to the notice periods for emergency works. So, if works start too late for a notice to be provided on the final working day of the 1992 Regulations, the notice is deemed to have been served the next working day and so should comply with the new regulations and notification requirements. The same principle applies to urgent works.

<b>Table B.1: Summary of transitional arrangements noticing summary</b>	
<b>When noticed</b>	<b>Consequence</b>
S54 notice given before 1 <sup>st</sup> April and works started before 1 <sup>st</sup> April	Follow 1992 Regulations and use existing EToN system up to interim or permanent reinstatement, whichever is earlier.
S54 notice given before 1 <sup>st</sup> April with planned start date before then, but works not started by 22 <sup>nd</sup> April.	S54 notice ceases to have effect and a fresh s54 notice should be given under 2008 Regulations if works are to proceed.
S54 notice given before 1 <sup>st</sup> April with start date before 30 <sup>th</sup> June	Notices under 1992 Regulations and use existing EToN system up to interim or permanent reinstatement, whichever is earlier.
S54 notice given before 1st April with STD after 30th June (in other words 1 <sup>st</sup> July or later)	Notice ceases to have effect and a new s54 notice should be made under new 2008 Regulations
S55 or s57 notice given before 1 <sup>st</sup> April and works started.	Follow 1992 Regulations and use existing EToN system up to interim or permanent reinstatement, whichever is earlier.
S55 given before 1 <sup>st</sup> April and works not started within 7 working days of start date.	No change; under s55(7) notice ceases to have effect.

## **B.4 Directions**

B.4.1 Directions under the powers in s56(1A) may only be given for works where the first notice of works is given on or after 1<sup>st</sup> April 2008.

B.4.2 Directions under S56A may only be made in relation to works for which a notice is given on or after 1st April 2008, when the 2008 Regulations come into force.

## **B.5 Restrictions following substantial road or street works**

B.5.1 The duration of a restriction following substantial road works made under the 1992 Regulations may not be longer than the 12-month period available under NRSWA before it was amended by the Traffic Management Act 2004.

B.5.2 The use of the new restriction of further street works following substantial street works may only be used in relation to works noticed on or after 1<sup>st</sup> April 2008.

## **B.6 Reinstatements**

B.6.1 Any reinstatement completed before the new regulations come into force, should following the requirements under the 1992 Regulations and NRSWA before amendment by the TMA. Therefore a notice of reinstatement should be provided by end of the next working day.

B.6.2 Reinstatements completed after 1<sup>st</sup> April 2008, but which were noticed before that date should comply with the 1992 Regulations and NRSWA before amendment by TMA.

B.6.3 Works that are noticed after 1<sup>st</sup> April 2008, including those to carry out a permanent reinstatement for works carried out under 1992 Regulations, should comply with the 2008 Regulations and inform the authority of the reinstatement within 10 days and provide all the information required.

## **B.7 EToN protocols**

B.7.1 The potential risks involved in all local authorities and statutory undertakers switching to the new EToN protocols at the same time have been noted. However, this is necessary if there is to be a common electronic system for serving and receiving notices. There is no requirement to change systems for storing, using or accessing such information.

B.7.2 Some local authorities and utility companies may wish to exchange test notices as part of the beta testing of the new software and procedures. This is good practice, but it is for local authorities and utilities to negotiate and agree.

B.7.3 The existing EToN protocols should be used for notifications under 1992 Regulations, for a limited period only – see B.8

## **B.8 End date for existing EToN system**

B.8.1 The existing system **should not be used to send or receive notices, covered by this Code four months** after the new regulations come into force. This limit has been set to minimise the time that local authorities and utility companies need to maintain and use both the existing EToN 3.0 system and EToN 4.0. Although works noticed before the date may need the EToN 3.0 to send and receive notices - such as actual

start of works, works closed, or works clear - in the overwhelming majority of cases this should be necessary for a maximum of four months.

B.8.2 A small number of major works will not be completed within four months of the introduction of the new notices Regulations and the XML EToN system. The highway authority and utility company concerned will need to agree arrangements for serving and receiving notices, especially works closed or works clear notices, for such works. The options include:

- using the EToN XML system, to send and receive notices, although automatic error checking may be an issue
- agreeing to allow use of the EToN 3.0 for notices for specific works or
- agreeing to the use of manual notices (no fee) for specific works.

## **B.9 Street Gazetteers and Additional Street Data**

B.9.1 Local highway authorities will need to review local street gazetteers before the new regulations come into force. They should ensure that existing requirements are met and identify any new information that must be included; for example, information on all streets in the area whether maintained by the local highway authority or not. This will include existing designations and restrictions.

B.9.2 Subject to the update timetable for the nationally consistent street gazetteer, it is expected that this should be completed within three months of the Notices Regulation 2008 coming into force.

## **B.10 Organisational data**

B.10.1 Local highway authorities will need to make provision for the transfer of data from all works promoters to the new system, including section 50 licensees.

B.10.2 The new EToN system will require additional data to be included in the ODD submissions to the NSG Concessionaire.

## **B.11 Fixed Penalty Notices**

B.11.1 Fixed Penalty Notices can be given only for offences set out in *The Street Works (Fixed Penalty) (Wales) Regulations 2008* (later referred to as FPN Regulations) and committed after these Regulations came into force on 12<sup>th</sup> May 2008. Any offence committed before that date will need to be dealt with at a Magistrates' Court.

B.11.2 Whether a particular case justifies giving an FPN or prosecution in the magistrates' court is a matter for each authority to decide, based on the facts of the case and its own independent legal advice. This should be borne in mind during the first three months of [Notices Regulations 2008], while the new system is embedded, and staff, both within local authorities and statutory undertakers, build experience and understanding of the new regime.

B.11.3 As set out in 11.7, the introduction of a fixed penalty notice scheme is **NOT** intended to be an additional source of income for street authorities. The street authority should therefore not expect, nor plan its expenditure, on the net proceeds from a fixed penalty scheme.

# APPENDIX C WORKS AT OR NEAR LEVEL CROSSINGS

## C.1 Purpose

Safety precautions for street works and other road works carried out in the street/road in the vicinity of Network Rail level crossings are described in legislation specific to street works and health and safety. These guidelines have been developed in the light of experience gained following incidents where collisions occurred from traffic tailing back across level crossings, even though the work sites were a considerable distance away. The available advice has been brought together for the first time in this Appendix, to provide comprehensive guidance for all those carrying out street works and other road works at or near to level crossings.

C1.1 References within this Appendix to the **appropriate National Authority** refer to:

In England, the Secretary of State for Transport

In Scotland, the Scottish Parliament

In Wales, the Welsh Ministers.

## C.2 Scope

This appendix specifies requirements for the execution of all works in the street/road at or near Network Rail level crossings. These should be identified in the National Street Gazetteer/Scottish Road Works Register.

This appendix applies equally to undertakers, highway/road authorities and others who execute works at or near level crossings. Access to, or work within, other Network Rail property is subject to separate safety requirements, details of which can be obtained from the normal Network Rail contact.

It applies to works that take place within the boundary of the level crossing, in the highway immediately in the vicinity, or some distance away where traffic may tail back across the level crossing as a result of the traffic management system employed during the works.

C.2.1 It does **NOT** apply to:

- a) Railways not owned by Network Rail. However, the advice is equally applicable to other railway authorities. It is strongly recommended that these principles be incorporated into appropriate arrangements for works at level crossings on railways not owned by Network Rail
- b) Non-public road level crossings e.g. farm access where all relevant legislation should be taken into account when processing these works. For example:
  - Undertakers may have particular powers under their enabling legislation and wayleave or easement agreements may apply in a particular case
  - Undertakers must ascertain what requirements apply before discussing their proposed works with Network Rail
- c) Street/road running tramways.

A working party representing the Highway Authorities and Utilities Committee (HAUC) and Railtrack plc prepared the original guidelines. These have subsequently been

revised for this document in co-operation with Network Rail Infrastructure Limited, HAUC-UK, RAUC(S), Welsh-HAUC and DfT and Transport Wales.

Network Rail is responsible for the maintenance of all infrastructure assets and for the day-to-day management of operations on the mainline railway. The provision of train services and associated activities are the responsibility of individual train operating companies.

Regional HAUCs in England, Welsh HAUC in Wales and Area RAUCs in Scotland, as appropriate, should be the first point of contact for any queries relating to policy matters or interpretation of this Document. It is intended to post the addresses of Secretaries of Regional HAUCs on the HAUC(UK) website ([www.haucuk.org](http://www.haucuk.org)).

### **C.3 Legislation**

For works at a level crossing, those undertaking the works must comply with the reasonable requirements of Network Rail made under Sections 93 and 152 of the New Roads & Street Works Act 1991. All parties concerned must comply with the reasonable requirements of Network Rail made under the Health and Safety at Work Act 1974 (HASWA) and its associated Regulations (in particular the Construction (Design and Management) Regulations 2007 (CDM) and Management of Health and Safety at Work Regulations 1999).

### **C.4 Special Features of Level Crossing Work**

#### **C.4.1 Works at or near level crossings**

Works at or near level crossings may impact upon one or more of the following:

- Safety of road users, pedestrians, railway passengers and personnel
- Train operation
- Structural integrity of the permanent way and other railway infrastructure assets
- Railway overhead traction cables, electrified third-rails and feeder or continuity cables
- Railway underground apparatus serving the railway and running parallel to it

Undertakers, the highway/road authorities, Network Rail and others carrying out street or road works and other works have a duty to co-ordinate their activities and to follow the special safety precautions which apply at level crossings. Risk Assessments with continuous monitoring, are essential to safe operation of street works at or near to level crossings.

#### **C.4.2 Safety of road users, railway passengers and employees**

Risk assessments must be carried out both before and during street works at or near to level crossings in order to minimise the risk. Safe systems of work must be in place and maintained during the street works. Risk Assessments are further described in section C7.

Traffic that stops or moves slowly over a level crossing causes potential danger to road and rail users alike.

Particular attention must be paid to situations where street works may be a considerable distance away from the crossing, as they may cause traffic tail backs over



the crossing.

### **C.4.3 Other safety issues**

When work is being carried out in the vicinity of overhead traction cables, electrified third rails and feeder or continuity cables, great care must be taken to avoid danger from electrocution. This is considered further in Section C8.

Electronic pipe and cable location equipment can potentially interfere with railway signalling apparatus and must not therefore be used within railway land without express permission from Network Rail, who will advise on the circumstances and type of equipment which apply at each level crossing that can be used at a particular location.

### **C.4.4 Network Rail's responsibility**

Network Rail will decide, on the basis of the information received from those proposing to execute street works, whether the street works are likely to affect train operations and advise of the arrangements made. Network Rail's Special Requirements are further described in Section C8.

For street works at a level crossing, those undertaking the street works must comply with the reasonable requirements of Network Rail made under sections 93 and 152 of the Act. In view of the requirements of the Rail Regulator, timing directions given under sections 93 and 152 may entail considerable delays to the project, and therefore it is recommended that consultation with Network Rail take place at the earliest possible opportunity. All parties concerned must comply with the reasonable requirements of Network Rail made under the Health and Safety at Work etc, Act 1974 (HASWA) and its associated Regulations (in particular the Construction (Design and Management) Regulations 1994 (CDM).

The whole of Network Rail's rail network infrastructure is a continuous site for the purposes of CDM. When work is being planned to take place on or in the immediate vicinity of a level crossing, and in order for permission to be given for any street works to commence, Network Rail will require details of the street works and the competence of those employed to carry out the street works, and will advise contact details.

Network Rail must assess the possible effects of street works on the permanent way (the railway track, sleeper, ballast or other foundation material) or adjacent Network Rail land, the level crossing surface, overhead catenary supports, signalling equipment and underground railway apparatus etc. and advise on the adoption of any additional measures required.

## **C.5 Designation**

In order to assist street works promoters in fulfilling the obligations set out herein, it is recommended that the location of level crossings, and where applicable an associated Precautionary Area, where special controls will apply, should be identified and publicised using the National Street Gazetteer or the Scottish Road Works Register, as appropriate.

This information is to be provided in the form of a Special Designation File added, as appropriate, to either:

- The National Street Gazetteer by Network Rail in accordance with the procedures laid down by the National Street Gazetteer concessionaire or,
- The Scottish Road Works Register in accordance with the procedures laid down by RAUC(S)

Highway/Road Authorities should cooperate with Network Rail in following the designation procedure set out below, in order to identify each level crossing and to establish an initial footprint of street/roads that will comprise the Precautionary Area.

Undertakers and other street works promoters should recognise that both NRSWA and HASWA require them to consider the implications of their street works and identify the effects on traffic in the vicinity of level crossings. They should therefore co-operate in the initial establishment of the Precautionary Area and its development over time.

### **C.5.1 Identification of the Precautionary Area**

Network Rail must identify individual level crossings, together with the Precautionary Area, and input this information into the National Street Gazetteer ASD data or the Scottish Road Works Register, including an indication of the position of the crossing, its type and whether any barriers are manually or automatically controlled.

Network Rail using the street authorities' local knowledge and in co-operation with them and local undertakers, will examine each crossing to identify those streets/roads associated with it that are likely to cause traffic tailbacks to the level crossing arising from street works carried out in the highway.

The exercise should identify each street/road falling wholly or partly within 200 metres of each crossing when following a route leading from the crossing.

The whole, or part of, each street/road identified above, will become part of the Precautionary Area and subject to special controls as described below. Minor modifications may be made at this stage, for example, the exclusion of one-way streets/roads with traffic flowing **towards** a level crossing.

### **C.5.2 Monitoring the Precautionary Area**

The initial footprint of the Precautionary Area is to be kept under review by Network Rail, utilising the Highway/Road Authority's local knowledge. Therefore, Promoters of any works are to check the National Street Gazetteer/Scottish Street Works Register to ensure that they are aware of the extent of the current precautionary area.

## **C.6 Consultation**

Street/Road Authorities have a duty under the Act to co-ordinate all kinds of street works in the street/road. Where this duty extends to street works that are likely to affect a level crossing, Network Rail must be included in the co-ordination exercise.

### **C.6.1 Co-ordination Meetings**

Network Rail may be expected to attend Co-ordination meetings when they are promoting street works. Network Rail may also be expected to attend when advised of proposed street works and other road works that may affect level crossings.

### **C.6.2 Advance Consultation with Network Rail**

Any planned street works which will take place at or near to a level crossing, or street works which are likely to affect the crossing because of traffic tailbacks (usually referred to by Network Rail as "blocking back"), must be advised to Network Rail's Outside Party Engineer for that location as early in the planning process as possible, but no later than one month in advance. The form shown in Annex A must be used for this purpose. The appropriate Outside Party Engineer can be identified from the map at Annex B

Upon receipt of advance advice of proposed street works Network Rail will endeavour to respond, within 10 working days, to acknowledge receipt of the advice and arrange to meet with the promoter to agree the special requirements to be included in the Health and Safety Plan for the street works. This meeting may take place at a Co-ordination Meeting or separately, depending on the nature and complexity of the proposed street works.

Confirmation of the agreed arrangements are to be given to Network Rail in writing one month before the street works are intended to start. Network Rail should then give its

approval of the street arrangements to the works promoter, within 10 days of receipt of the confirmation.

In the case of street authorities' street works for road purposes this will be the only notification required to be given to Network Rail. In the case of undertakers and others, statutory Notices under the Act will also be required. Promoters of works should also note that Where the level crossing has been designated on behalf of by Network Rail under the Act as a street/road with Special Engineering Difficulty, a plan and section drawing showing details of their proposed works undertakers and others may be required to accompany the advance advice described above, with a plan and section drawing showing details of their proposed street works.

### **C.6.3 Undertakers' Statutory Notices under the Act**

Sections 93(2) or 152(2) of the Act require undertakers to give notice to Network Rail of the starting date of proposed street works which are to take place at a level crossing, notwithstanding that such notice is not required under section 55 (notice of starting date).

### **C.6.4 Minimum Notice Periods**

It is strongly recommended that notice periods are treated as the minimum periods and, wherever possible, longer notice should be given. This is particularly important in the case of level crossings, where Network Rail may have to make special arrangements ranging from the provision of railway safety cover to complete closure of the rail route and rearrangement of rail services while the Street works take place.

### **C.6.5 Immediate Works**

Where it is necessary to carry out immediate works at or near to a level crossing it is vital that the street authority and local Network Rail office is contacted immediately and work is not commenced until the promoter has been assured that all necessary safety precautions are in place.

### **C.6.6 Street works licences/road works permissions**

Those without a statutory right to carry out street/road works must be authorised by the Street/Road Authority (i.e. the Highway/Road Authority or Street/Road Managers) by means of a licence/permission before works may commence. In addition, the holder of the licence/permit may have to comply with the requirements of other relevant authorities or owners of apparatus affected by the work. In some cases it may be necessary to settle a plan and section. It is recommended that specific reference to this guidance should be made within licences for works in the vicinity of railway level crossings. Network Rail, as the Street/Road Manager at the level crossing, will similarly ensure that the requirements of this guidance are followed when licences or permissions are issued.

### **C.6.7 Unqualified staff within the railway boundary**

If it is necessary to use promoter's personnel to execute works within the track area they must not be allowed to enter until Network Rail nominated personnel have arranged appropriate protection and confirmed that it is safe to do so (see Section C8).

## **C.7 Risk Assessments and Traffic Control**

### **C.7.1 Codes of practice and other advice**

The Code of Practice Safety at Street Works and Road Works issued under sections 65 and 124 of the Act is based on the Traffic Signs Manual (Chapter 8) and is a statutory requirement for undertakers' street/road works. It specifies the basic

requirements for signing, lighting and guarding and traffic control at street/road works.

Chapter 8 of the Traffic Signs Manual 2006 also gives specific advice on traffic control at railway level crossings.

### **C.7.2 Risk Assessments**

Risk Assessments are a requirement of the Construction, Design and Management Regulations 1994 and Health and Safety at Work Regulations 1999 and it is particularly important that they are carried out at railway Network Rail level crossings.

Arrangements made as a result of Risk Assessments should be continuously monitored so that appropriate remedial measures can be taken quickly if required.

Risk assessments should take into account the distance of the crossing from the proposed street works and the volume of traffic using the road. Particular attention must be given to the possibility of traffic congestion tailing back over a level crossing at any time during the duration of the street works, for example during an all-red traffic light period imposed to allow difficult operations to take place at the work site. There have been instances where this situation has also arisen from street works that have been a considerable distance from the level crossing and this possibility should always be borne in mind during street works.

### **C.7.3 Traffic Control Measures at or near Network Rail Railway Level Crossings**

Traffic control at or near level crossings are to be in accordance with the guidance set out in Chapter 8 of the Traffic Signs Manual 2006

- Part 1 Design: D5.15.
- Part 2 Operations: O3.24

## **C.8 Network Rail's Special Requirements for All Works Affecting the Permanent Way**

Network Rail's Special Requirements must be followed in all cases where street works are to take place at a level crossing and should be included in any contract let in connection with the street works. The current version of this document may be obtained from Network Rail, who will also be able to give advice during the planning of street works.

There is no provision in the Act for the recovery of costs for special arrangements such as those described below and costs incurred by each party will therefore lie where they fall.

### **C.8.1 Level Crossing Attendant**

A Level Crossing Attendant will ensure the crossing is cleared before lowering barriers and authorising a train to movement

### **C.8.2 Temporary Speed Restrictions**

In some instances it may be necessary to impose a temporary speed restriction on trains. Temporary speed restrictions take time to arrange, so discussions with Network Rail should take place as early as possible, before any formal notice is given for the street works. Where a temporary speed restriction may already have been arranged for other purposes, the highway/road authority, undertaker or other person should consider rearranging the timing of its street/road works so as to be able to make use of it, thereby minimising disruption to rail traffic.

### **C.8.3 Trenchless Construction**

Where trenchless construction is to be employed beneath the railway track, Network Rail must approve the method. A temporary speed restriction may be imposed on trains and Network Rail may require to oversee street works in progress. Pipe bursting techniques will require special consideration by Network Rail, due to possible effects on the permanent way.

### **C.8.4 Street/road works on railway land that do not affect the structure of the permanent way**

These are street works that do not affect the track or its surrounding land, such as street works at a manhole, erection of poles and wires, pressure testing pipes which do not pass under the track or excavations several metres away from the track.

### **C.8.5 Street Works outside the confines of a level crossing, using existing ducts which pass beneath the railway.**

These works may proceed without special early notification to Network Rail. However, Risk Assessments and Traffic Control as described in Section C7 must be followed.

### **C.8.6 Use of mechanical excavators and cranes near the railway**

Network Rail will advise of any necessary precautionary measures whenever cranes, mechanical excavators, vehicles or other construction plant is to be operated close to railway traffic. The purpose is both to protect trains from accidental contact with the plant and to protect operators from the likelihood of death or serious injury arising from contact with live traction equipment and trains on the railway.

Network Rail may require the submission of plant operating diagrams and/or method statements, prepared by the plant operator and approved by the undertaker, highway authority or other person carrying out the work, to enable it to decide the magnitude of any potential problems. These diagrams and method statements should take into account the possible results of machine failure, structural failure or uncontrolled operation of the plant.

### **C.8.7 Electrification continuity cables**

In areas where the railway is electrified using the third rail system particular care must be taken to ensure that continuity cables, which connect the ends of the live rail to maintain electrical continuity, are not damaged whilst excavations are being undertaken. In most cases these will be laid parallel to the rails at, or just below, the adjacent ground level.

## **C.9 Reinstatement of the Road at Level Crossings**

Where the Highway/Road Authority resurfaces a road or carries out alterations on the approach to a level crossing, alterations should not be made to any signs or road markings which are a requirement of the Level Crossing Order, including carriageway and footway width and centre of carriageway markings on the approach to the crossing. If alterations are required sufficient notice is required to permit Network Rail to request and obtain a revised Level Crossing Order.

## **C.10 New Works near Level Crossings**

When undertakers are proposing to install new supplies, routes should wherever possible avoid traversing level crossings. Where avoidance is not possible, trenchless methods of installation should be considered.

## **C.11 HM Railway Inspectorate's Requirements**

Specific attention is drawn to HM Railway Inspectorate Guidance Note, 'Railway Level Crossings' dated 1st May 2003 and the necessity to comply with the advice contained therein.

**Annex A**

<b>ADVICE OF INTENDED WORKS AT OR NEAR A RAILWAY LEVEL CROSSING</b>	
To: (Name) (Company) (Address) Tel No: Fax No: Date: .....	From: (Name) (Company) (Address) Tel No: Fax No: Sender's Ref No: .....
<p style="text-align: center;"><b>PRELIMINARY ADVICE</b></p> <p>Works are proposed at/near the level crossing at: _____ (street/road name, railway line)</p> <p>Details of the works are given in the attached description/ plan and section*. Intended start date of works .....</p> <p>Likely duration of works.....</p> <p style="text-align: right;">*delete as appropriate</p>	
<p style="text-align: center;"><b>ACKNOWLEDGEMENT OF RECEIPT OF ADVICE (by Network Rail)</b></p> <p>Details of your proposed works, Ref No: _____, has been received. The person dealing with the proposal is: (Postal Address)</p> <p style="text-align: center;">Tel No: Fax No: E-Mail:</p> <p>The proposal has been given the Network Rail Ref No:</p> <p>*The works are not yet approved. We will be in contact again by (date) _____ to arrange a meeting.</p> <p>*Please re-submit your proposal, it must incorporate Network Rail's Special Requirements, a copy of which is attached.</p> <p>*The works may proceed in accordance with the Arrangements set out in your proposal. This Form and a copy of the Arrangements have been forwarded to the Highway/Road Authority for their information.</p> <p>Signed for Network Rail _____ Date _____</p> <p>*delete as appropriate</p>	

# Annex B

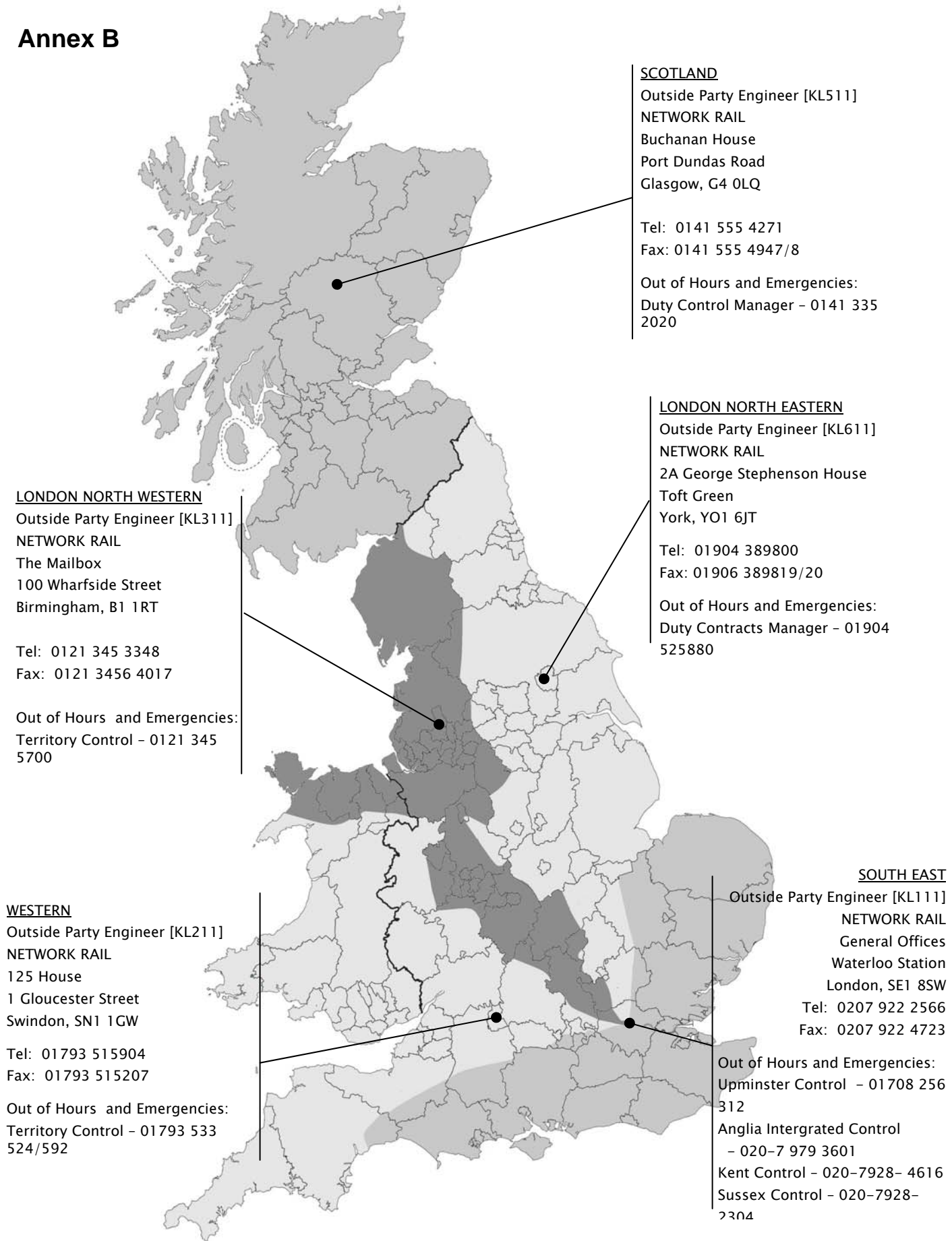



# APPENDIX D WORKS NEAR HIGHWAY STRUCTURES

## D.1 Introduction

This appendix has been modified from a document prepared by the CSS (formerly the County Surveyors' Society) in consultation with HAUC (UK). It is addressed to undertakers; also contractors, engineers, developers, planners and others involved in excavating the highway, particularly for the installation and maintenance of underground apparatus in the street in close proximity to highway structures, but would apply equally to any other engineering structure that might be affected by the works. It reiterates the importance of prior local liaison and consultation as a means of avoiding subsequent problems. Although this appendix has been prepared by the CSS primarily for the protection of structures owned by highway authorities, the same principles apply to structures owned and maintained by other authorities, such as Network Rail, London Underground, the British Waterways Board and others, and therefore all references in this appendix to "highway structures" should be deemed to apply equally to structures associated with the highway but owned by other authorities.

### D.1.1 Purpose

The purpose of this appendix is to recommend ways in which the risk of damage to highway structures from works may be averted, firstly by providing information on how to identify structures, then to advise on safety measures to avoid damage occurring. It also seeks to promote uniformity of approach amongst street and bridge authorities and undertakers towards the provision of services across or alongside highway structures. It reminds undertakers of the special statutory arrangements already in place for many of these structures and draws attention to the presence of others which may nevertheless be at risk of damage and require special care to be taken during street works.

In order to avoid damage to highway structures, personnel engaged in works should be able to:-

- a. appreciate the likelihood of highway structures being affected by works, the need for special care to be taken and the damage which can easily result from a moment's carelessness or ignorance
- b. recognise types of highway structure and be aware of the problems and damage that can arise if the correct procedures are not followed and also be able to recognise parts of the structure that may be exposed by excavation during works
- c. be aware that highway structures designated as being of Special Engineering Difficulty (SED) are subject to special statutory arrangements which set down the procedures which street authorities and undertakers need to follow before street works begin
- d. be aware that other highway structures which may not have been designated as in (c) above, nevertheless require special care and consultation during street works
- e. be aware that traffic management arrangements during works may redirect traffic onto weak areas of a structure.

### D.1.2 Scope

This appendix should be considered when new services are to be provided or when apparatus is to be exposed or maintained in proximity to any existing highway structure.

### D.1.3 Background

Highway structures form an essential part of the highway infrastructure that require special consideration and care when work is undertaken in the street.

Society expects the provision of services (electricity, gas, water, sewerage, telecommunications etc) each of which requires an extensive distribution network.

Space is often very restricted in and adjacent to highway structures and services may have to share a congested service bay within the structure. In order to satisfactorily install, operate and maintain services in such situations, the needs of the structure owner, street authority and undertakers must be jointly understood and appropriate precautions taken to minimise the risk of damage.

As with all guidelines, the interpretation and application of this appendix should be tempered at all times by good engineering judgement. The emphasis throughout is on the need for local liaison and consultation.

## D.2 Highway Structures

Highway structures may be of various different forms, sizes and degrees of importance. They all need great care to be taken by those executing street works in their vicinity. They may be composed of a variety of materials, e.g. brick, stone, concrete, steel, wrought or cast iron, timber or a combination of these and other materials.

They include, among other things: -

- bridges (road, rail)
- flyovers
- underpasses
- subways
- viaducts
- aqueducts
- culverts
- cattle-creeps
- cellars
- sign-gantries
- tunnels
- pipes
- corrugated steel pipes
- footbridges
- safety barriers
- retaining walls
- high mast lighting columns
- reinforced earth structures.

Highway structures are expensive and intricate, requiring great care and attention on the part of those installing services or repairing apparatus in their vicinity. What might appear to be minor and insignificant damage to a vital structural element may affect its safety and durability and thus substantially reduce the serviceable life of the structure. Such minor damage may remain undetected for years, but the consequences and the ultimate cost of repair could be severe.

Modern highway structures have a design life of 120 years. Most are unique, though a large proportion of structures will fall into one of a small number of structural types. Using a few basic principles and working methods will help to safeguard their structural integrity and preserve them from damage. Annex 1 shows typical structure types and restricted zones that may be designated by the owning authority.

Many are either scheduled ancient monuments or listed buildings, having protection under Acts of Parliament against unauthorised street works that may damage their archaeological importance or special architectural or historic interest. See Section D.4.

Particular care must be taken with the reinstatement of 'high amenity surfaces' on or adjacent to highway structures designated as scheduled ancient monuments or listed buildings or located in a conservation area where their contribution to the special architecture or historic interest may be very significant. The HAUC Specification for the Reinstatement of Openings in Highways (S8.3.2) gives the reinstatement requirements for high amenity surfaces.

Some structures are protected by a waterproof membrane to combat the effects of corrosive de-icing salts which may penetrate the road surface. The membrane may be mastic asphalt, rubber or polymerised sheet or a thin spray-on layer. Even minor damage to this during installation of a service can cause the problems highlighted in D.2 resulting in serious consequences to the integrity of the structure.

Similarly many structures have movement joints either at or below the carriageway surface to accommodate expansion and contraction. There are many different types of joint: some buried, some exposed, some open and some sealed to prevent ingress of water. Minor damage to these can also have serious long-term consequences to the integrity of the structure.

During the installation of services and maintenance of apparatus, the type of plant and equipment used for excavation and breaking out may potentially be very damaging to structures and their components unless operated with extreme caution.

During construction of a new bridge or major maintenance work to an existing bridge, effective planning and liaison between street authorities and undertakers will often prevent future disruption and possible damage if additional ducts are incorporated within the structure at an appropriate stage. Such arrangements are likely to be in the interest of all parties and are in accordance with the principles embodied in the HAUC Code of Practice *Measures Necessary Where Apparatus is Affected by Major Works (Diversionary Works)*.

When planning a traffic management scheme for street works at or adjacent to a highway structure it is important to discuss signing, lighting and guarding arrangements with the street authority. Apart from following the requirements of the Code of Practice *Safety at Street Works and Road Works*, it is important to ensure that diverted traffic is not directed onto weak parts of the structure. It may also be necessary to erect screens to avoid debris falling through or over bridge parapets. It is also important to ensure that cables linking sets of temporary traffic signals used in connection with the street works are not allowed to sag over parapets and touch live overhead rail traction cables.

### **D.3 Prior Consultation**

Section 88 of NRSWA imposes an obligation on an undertaker proposing street works affecting the structure of a bridge to consult the bridge authority concerned (which may not necessarily be the street authority) before giving the usual section 55 notice and to comply with the reasonable requirements for safeguarding the structure. Annex 2 provides an example of a suitable consultation form and shows the information the bridge authority may require.

### **D.4 Ancient Monuments and Listed Structures**

Many highway structures are scheduled ancient monuments or listed buildings and protected against unauthorised street works that may damage their archaeological importance or special architectural interest. They range from milestones and mileposts to extensive medieval causeways and bridges. Great care is needed to avoid damage to these structures and almost invariably specific consent is required before work on them may be undertaken.

In some cases, from the nature of the structure, its listed status will be reasonably apparent, in others the undertaker may know of it from previous experience. Additionally, except in those cases where prior notice is not required, notification will provide the street authority with the opportunity to advise the undertaker of the presence of a listed structure. These cases highlight the merit of early liaison and consultation between all parties in order to avoid delays and the possible contravention of the legislation.

### **D.5 Specification for the Reinstatement of Openings in Highways**

Undertakers are under a duty to carry out their street works to prescribed standards. The Specification provides guidance on excavation, backfilling and reinstatement of the highway.

### **D.6 Responsibility for Damage**

Under section 82 of NRSWA an undertaker must compensate a street authority, other undertaker or any other relevant authority for loss caused by the execution of street works. This obligation is subject to the proviso that the authority itself has not, by negligence or misconduct, contributed to the loss. These provisions should encourage all parties to liaise and co-operate fully in all cases where it is known that sensitive structures may be at risk from street works.

### **D.7 Recognition of Structures**

Vigilance is required in the planning and execution of work. In the case of streets formally designated under section 63 as having special engineering difficulties the Regulations require details to be recorded by the street authority in the street works register. Where there is no

designation, the undertaker may be aware of a structure from previous experience or local knowledge. In such instances he will be aware of the need for care in carrying out the street works and can advise operatives and contractors accordingly.

Many highway structures are large and easily recognisable but a great number are not apparent to the casual observer. Cellars, culverts and tunnels are frequently not visible from the road or verge and it is not unknown for excavation to damage underpasses or bridges without operatives becoming aware.

A highway authority should be able to provide the location of highway structures in its ownership of which it is aware. It may also be able to provide sources of other information held on privately owned structures. Reference may also be made to other available information such as Ordnance Survey plans and records of previous installations.

It is important that notification procedures are correctly followed. Unclear or inaccurate notices may mean that the street authority is unable to spot a potential risk to a structure or, at best, unable to determine how a structure may be affected by the proposals.

Features to look for include coalholes, lower ground floors, basement accesses, light wells, manholes, or gardens at a lower level than the road. In rural situations, low points may indicate probable culvert locations where watercourses pass under the highway. In hilly terrain, retaining walls may be found which both support the road and adjacent land higher than the highway.

Undertakers are reminded of their responsibility to recognise when their proposed street works will affect a structure and to consult the bridge authority before giving notice.

## **D.8 Damage to Highway Structures**

This appendix sets out the procedures and precautions that should be taken in order to avoid damage to highway structures during street works. It also stresses the fact that apparently minor and insignificant damage to a vital structural element may substantially reduce its serviceable life and seriously affect its safety.

Even after taking all procedures and safety precautions into account, there may be occasions when damage nevertheless occurs. When this happens it is absolutely essential that the authority owning the structure is advised of the damage without delay so that timely repairs may be carried out. Minor damage can sometimes remain undetected for years, whilst the serviceable life and safety of the structure will deteriorate and repairs, when they are finally made, will undoubtedly prove very much more extensive and costly than if carried out immediately.

## **Annex 1**

### **Typical Structure Types and Restrictions**

- A. Figures 1 to 11 show some common types of highway structures that may be encountered, the terminology used, a typical Restricted Zone that may be designated by the owning authority, typical locations of bridge waterproofing membranes and some of the constraints that the authority may place on the installation of services within it. These are not exhaustive but purely indicative.
- B. Figure 1 shows a typical Restricted Zone that may be designated by a bridge authority. It will normally cover the entire width of the street and its length will extend 2 metres beyond each end of the parapet or rail. However, the extent of a designated Restricted Zone is subjective and all parties should adopt a flexible approach when considering individual circumstances to reduce the risk of damage to the structure during street works.
- C. All dimensions in Figs. 1 to 11 are in millimetres.

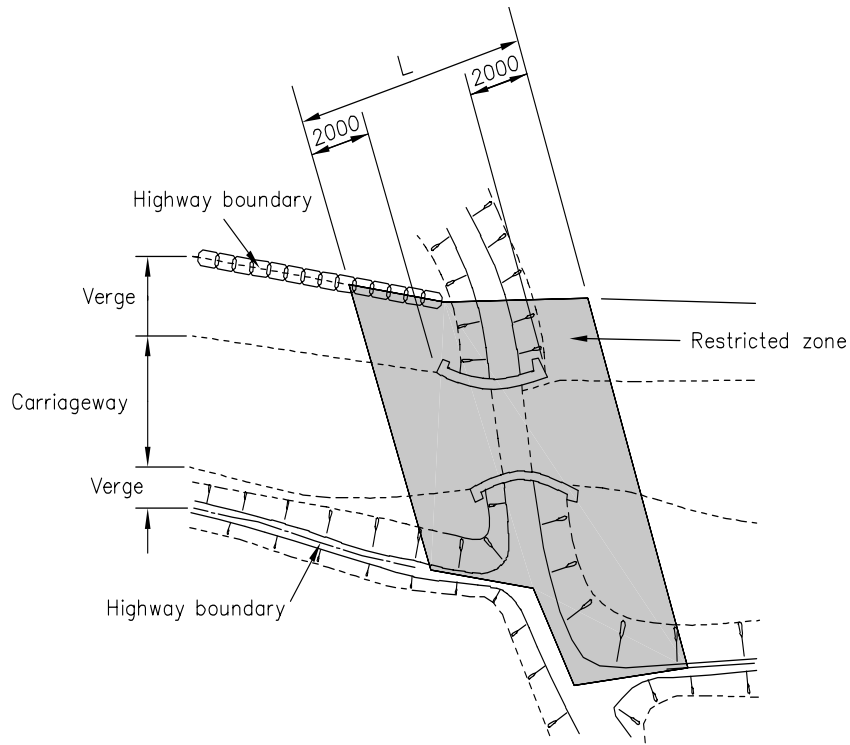

SINGLE SPAN ('OLD' ARCH OR CULVERT)

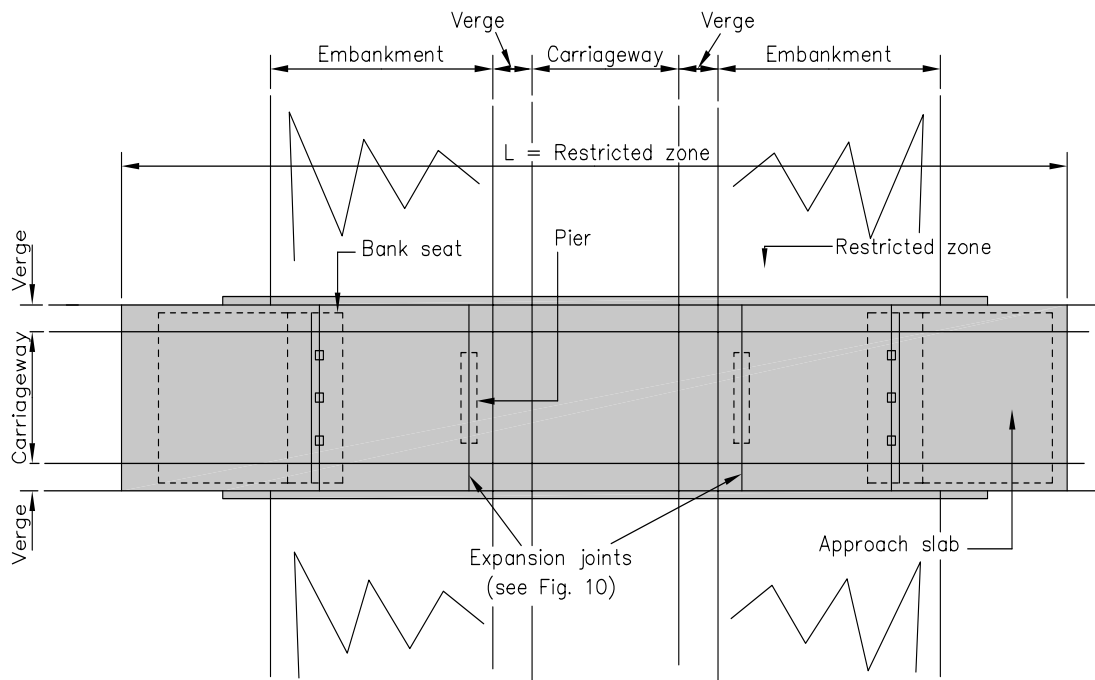

MULTI SPAN ('MODERN' BRIDGE)

Fig 1  
TYPICAL PLANS ON RESTRICTED  
ZONES AT STRUCTURES

Not to scale

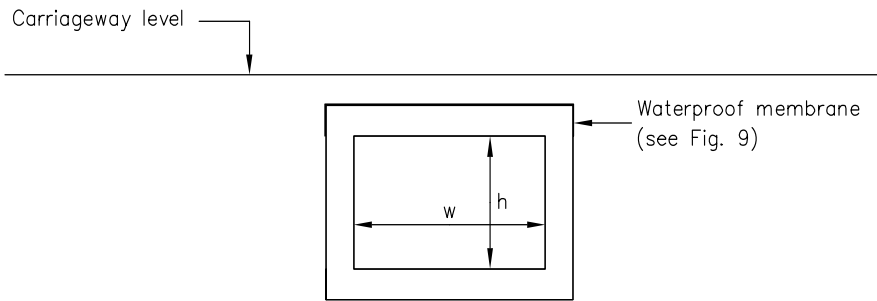
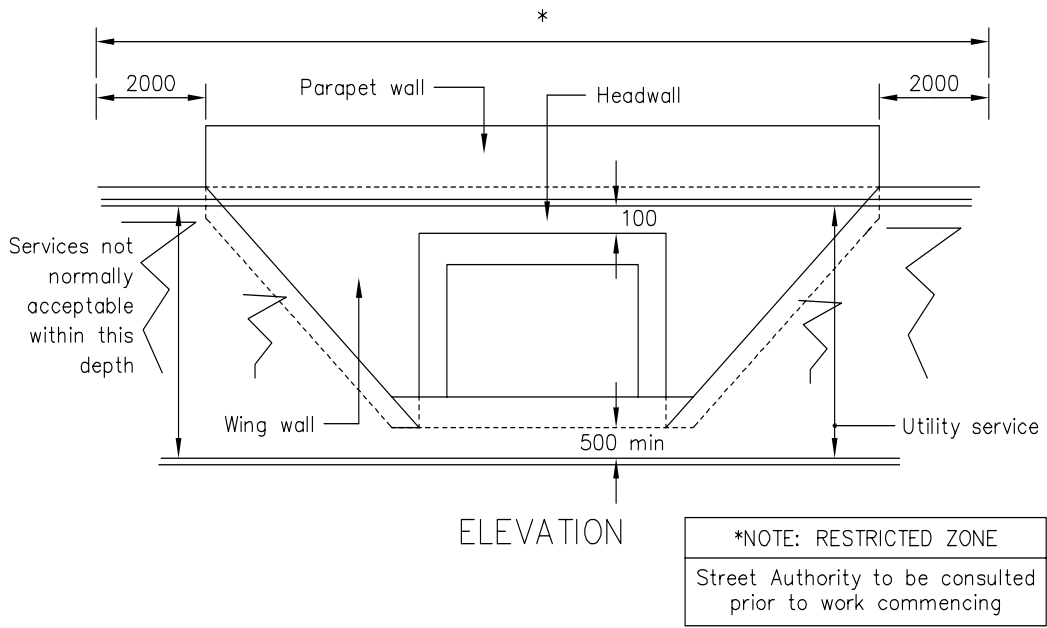

h - varies (0.75 - 3.0 m approx.)  
w - varies (1.0 - 4.5 m approx.)

CROSS SECTION (Parallel to road)

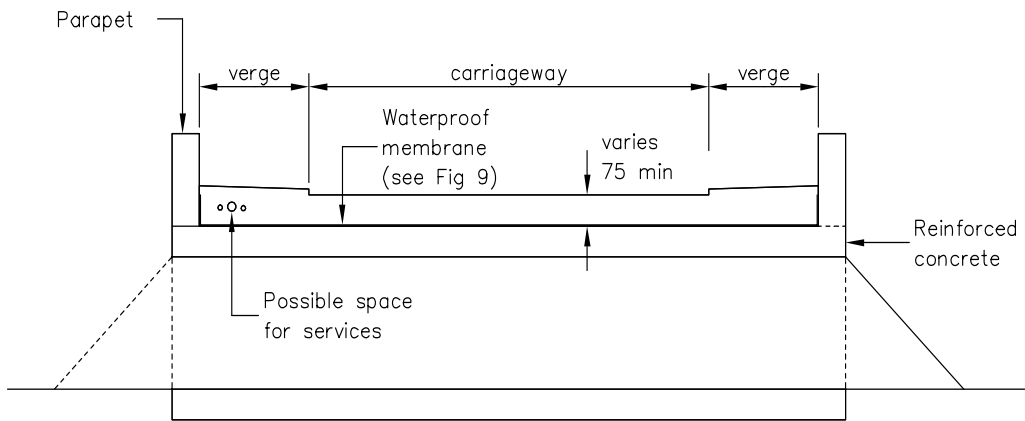

CROSS SECTION (At right angle to road)

Fig 2  
TYPICAL SUBWAY / BOX CULVERT  
Not to scale

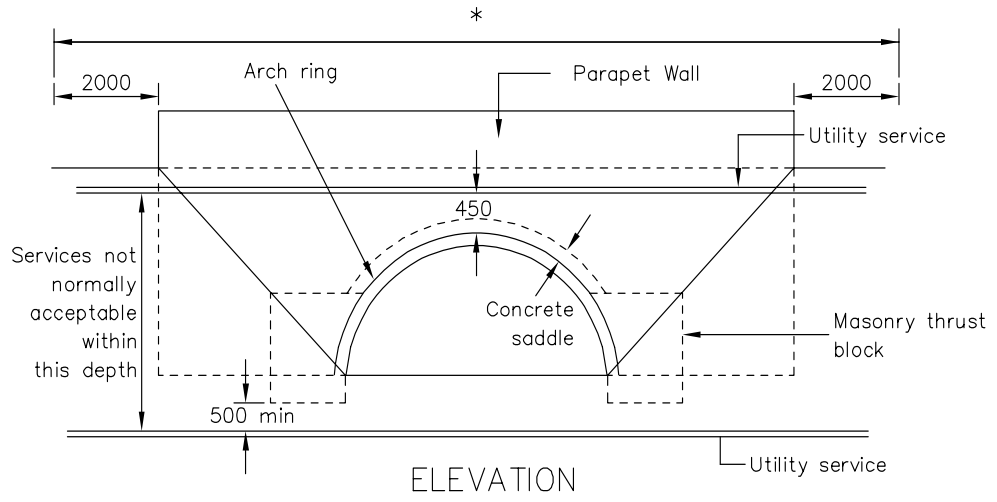

\*NOTE: RESTRICTED ZONE  
Street Authority to be consulted prior to work commencing

This surface could be jagged particularly if a stone arch. Care required not to damage or dislodge stonework.

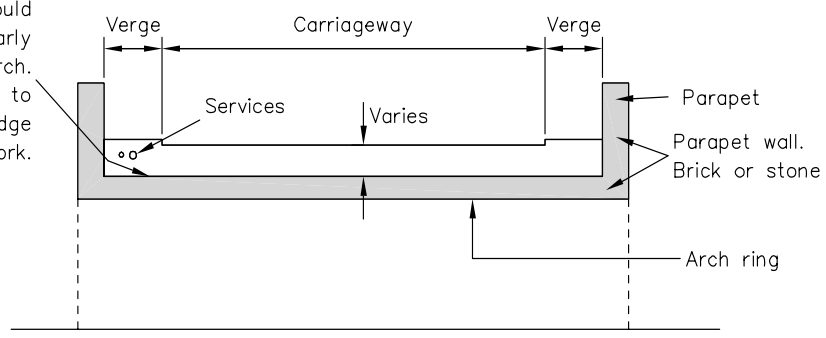

CROSS SECTION

(No concrete saddle or waterproofing)

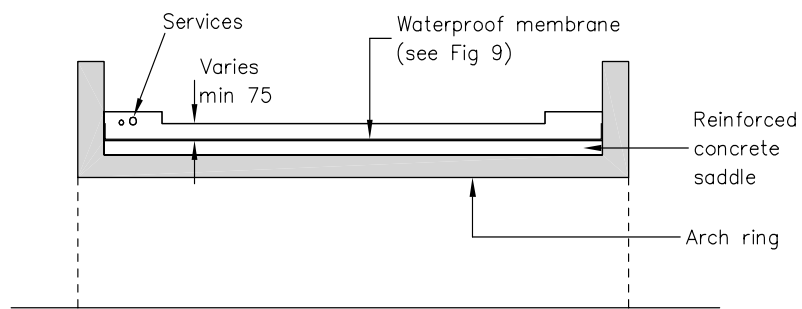

CROSS SECTION

(With concrete saddle or waterproofing)

Fig 3  
TYPICAL STONE/BRICK ARCH OR CULVERT  
Not to scale



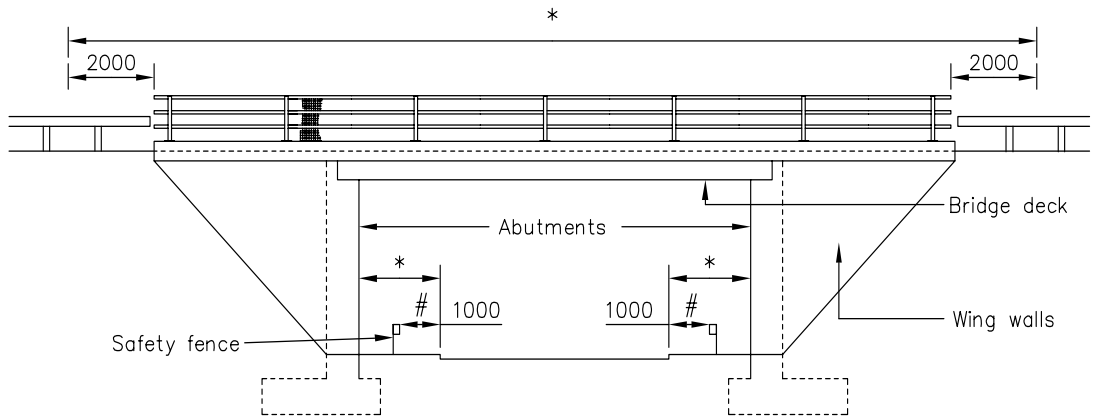

ELEVATION

# NOTE: RESTRICTED ZONE
Restricted zone adjacent to safety fence refer Fig 11

*NOTE: RESTRICTED ZONE
Street Authority to be consulted prior to work commencing

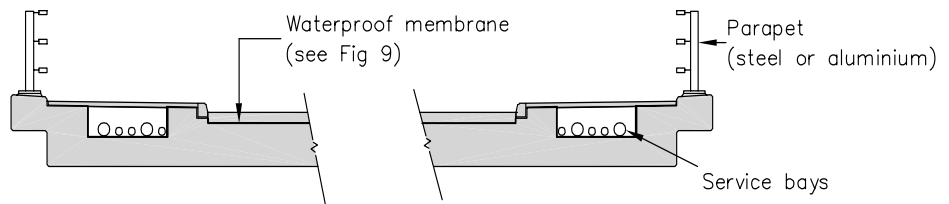

SECTION - WITH SERVICE BAYS

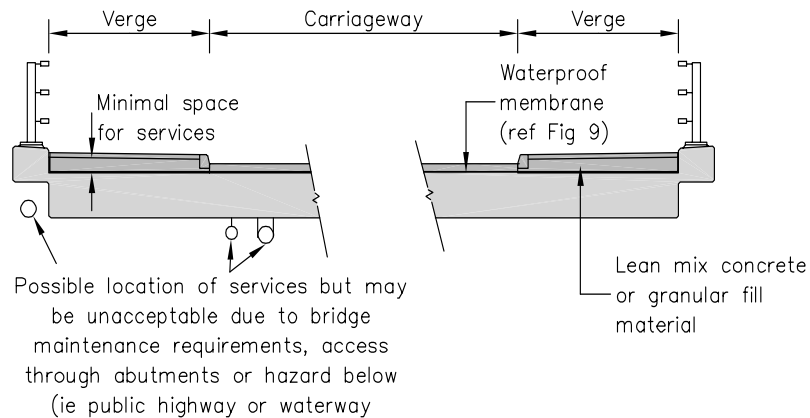

SECTION - NO SERVICE BAYS

Fig 4

TYPICAL SINGLE SPAN  
CONCRETE HIGHWAY BRIDGE

Not to scale

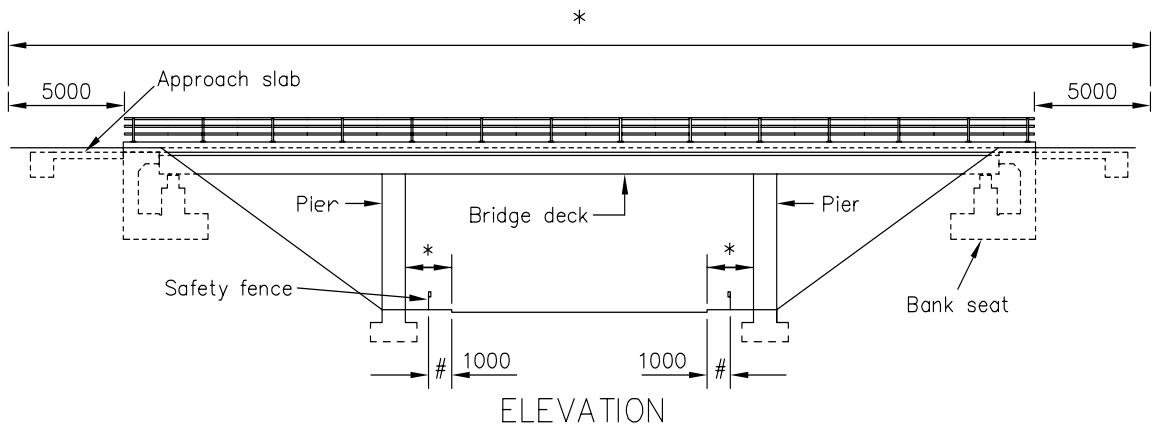

*NOTE: RESTRICTED ZONE
Street Authority to be consulted prior to work commencing

# NOTE: RESTRICTED ZONE
Restricted zone adjacent to safety fence refer Fig 11

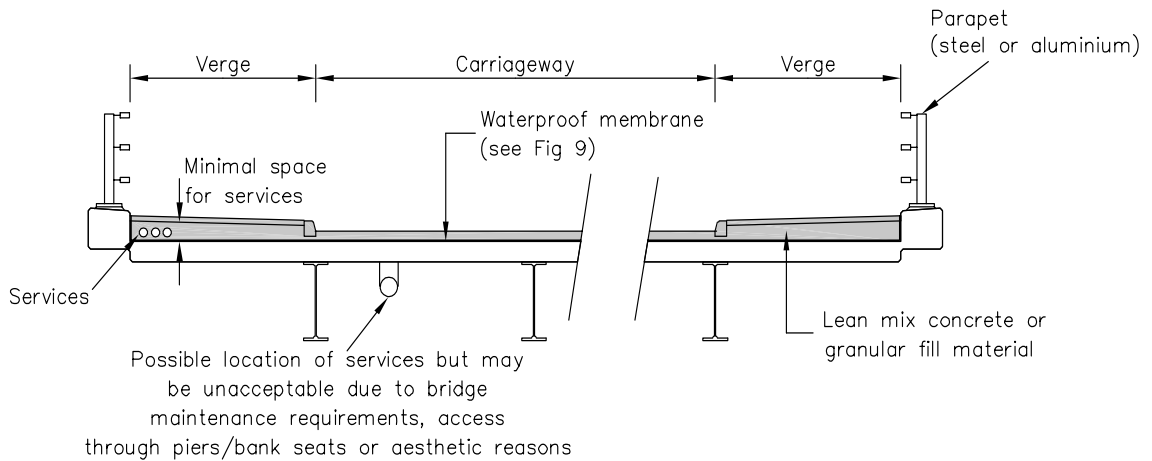
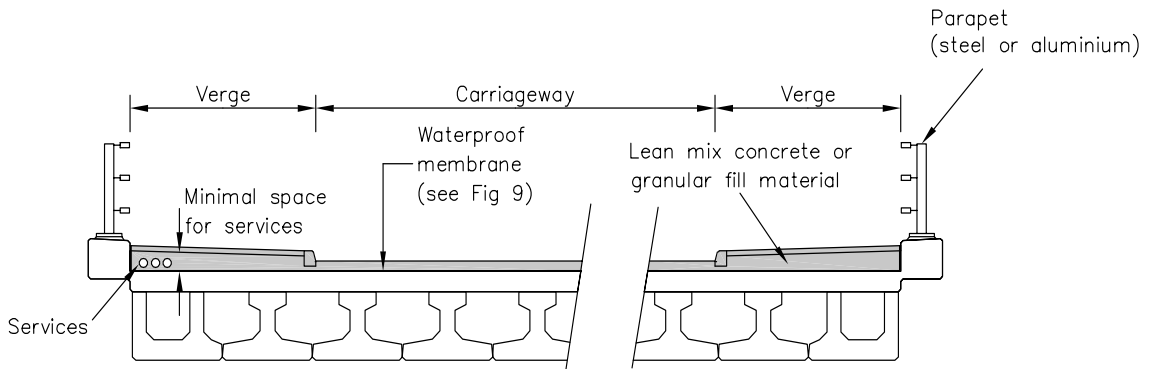
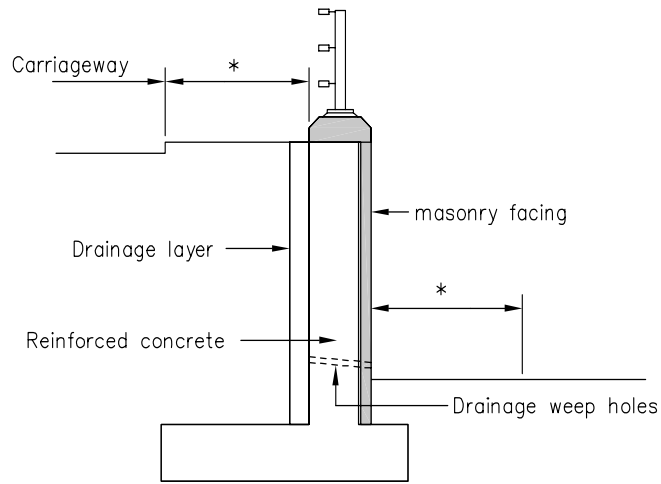
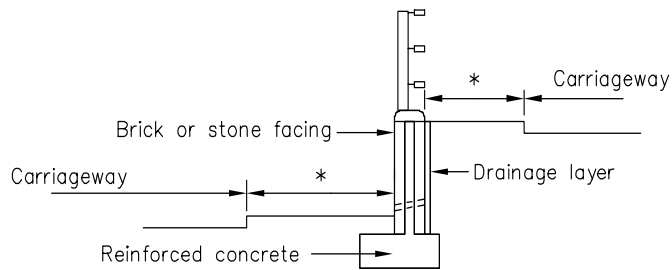

Fig 5  
TYPICAL MULTI-SPAN STEEL-CONCRETE  
COMPOSITE HIGHWAY BRIDGE

Not to scale



(a) REINFORCED CONCRETE WITH MASONRY FACING



(b) REINFORCED BRICK OR STONEMWORK

*NOTE: RESTRICTED ZONE
Street Authority to be consulted prior to work commencing

Fig 6  
TYPICAL RETAINING WALLS  
Not to scale

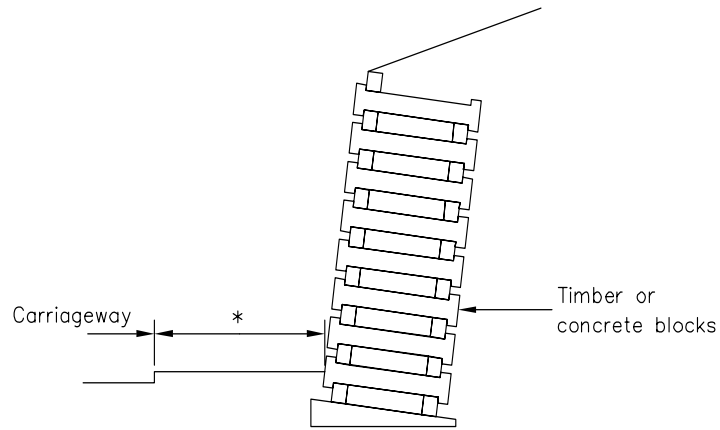

(c) CRIB WALL

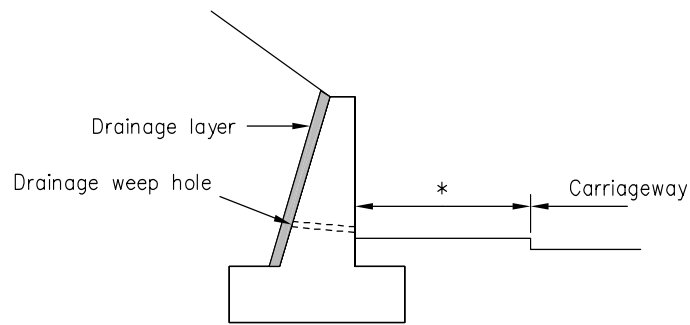

(d) MASS CONCRETE

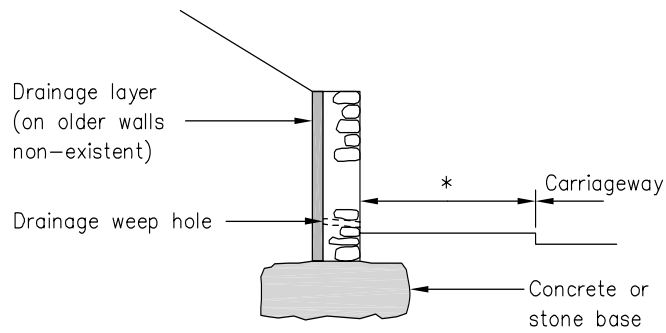

(e) STONE WALL

*NOTE: RESTRICTED ZONE
Street Authority to be consulted prior to work commencing

Fig 7  
 TYPICAL RETAINING WALLS (continued)  
 Not to scale

*NOTE: RESTRICTED ZONE
Street Authority to be consulted prior to work commencing

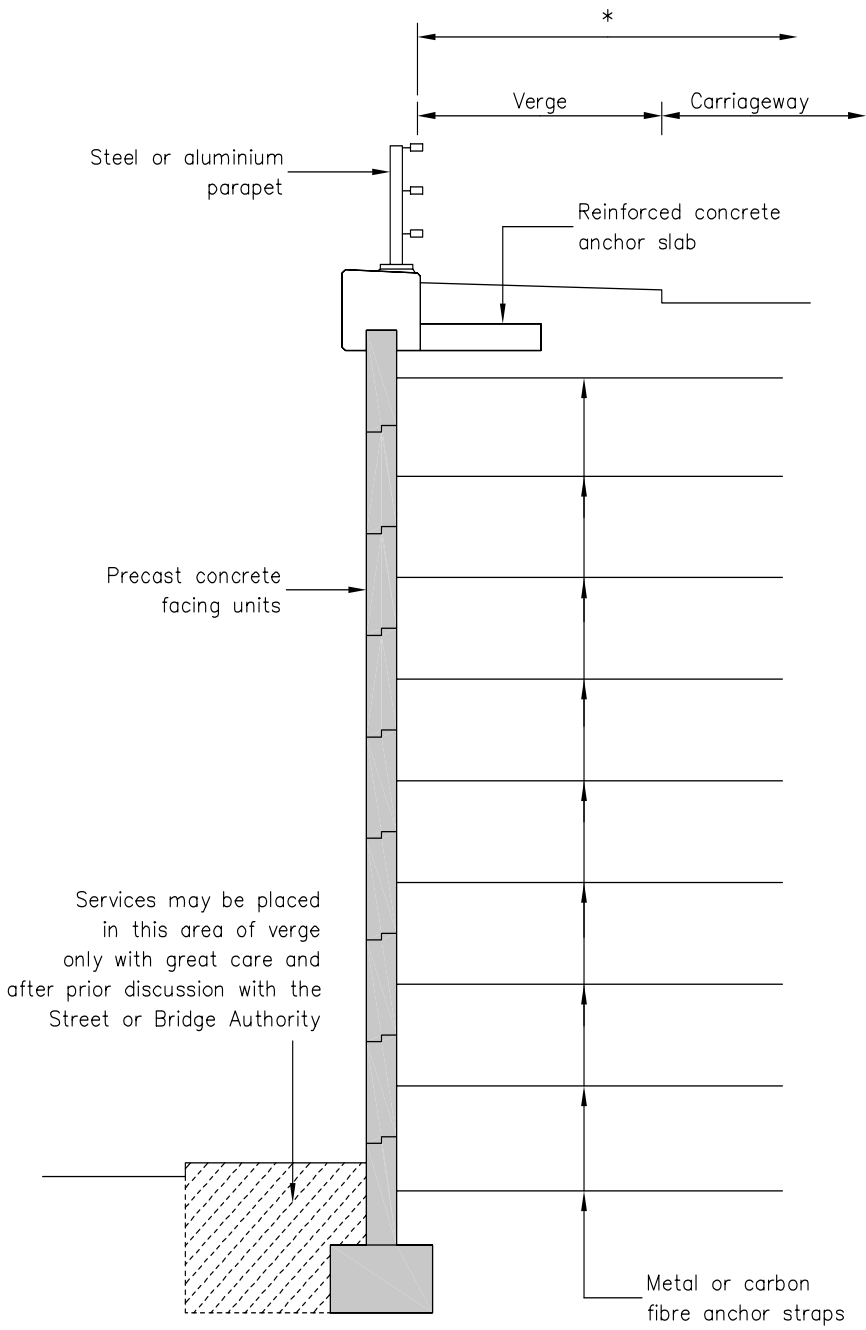
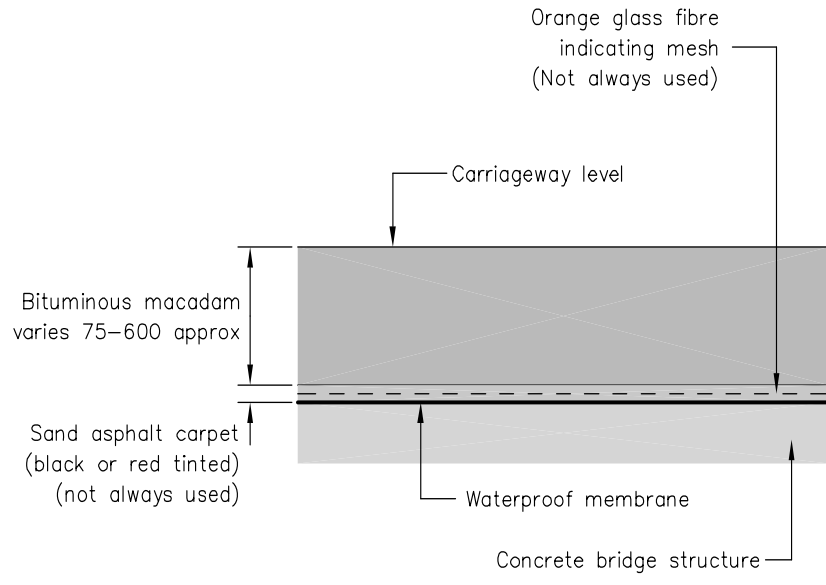
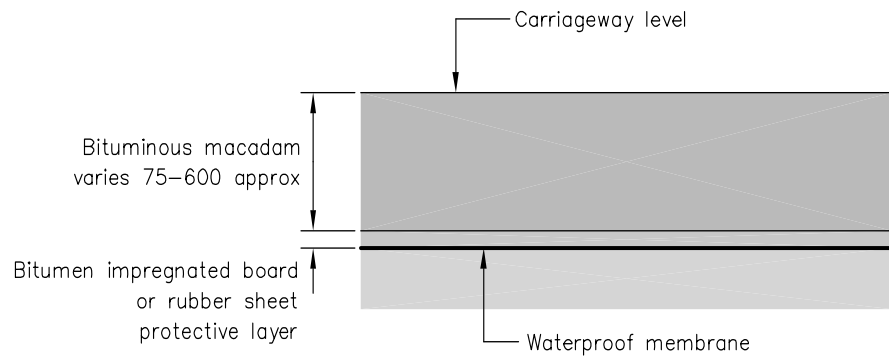

Fig 8  
 TYPICAL REINFORCED EARTH RETAINING WALL  
 Not to scale



(a)



(b)

Fig 9  
 TYPICAL  
 WATERPROOF MEMBRANE PROTECTION TYPES  
 Not to scale

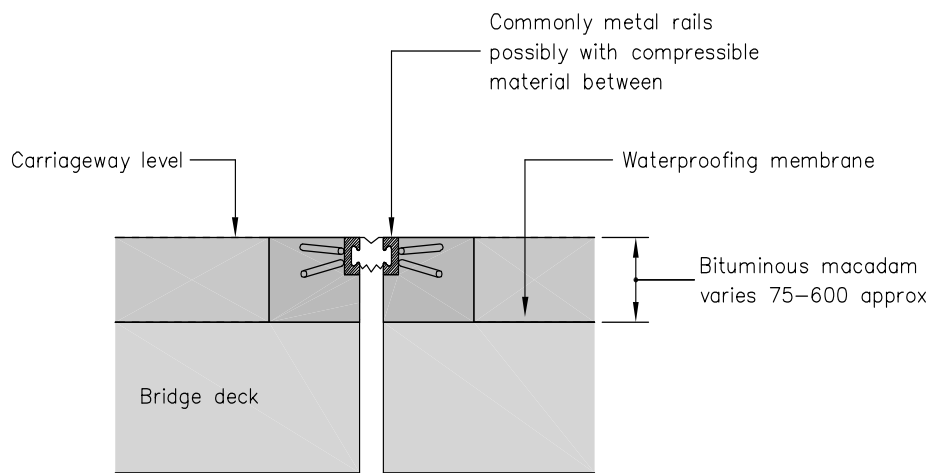

(a) EXPOSED JOINT

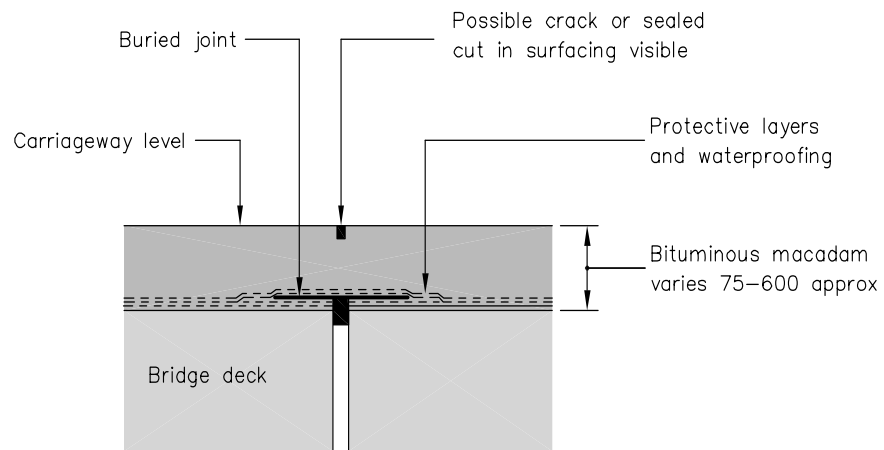

(b) BURIED JOINT

Fig 10  
TYPICAL EXPANSION JOINTS  
Not to scale

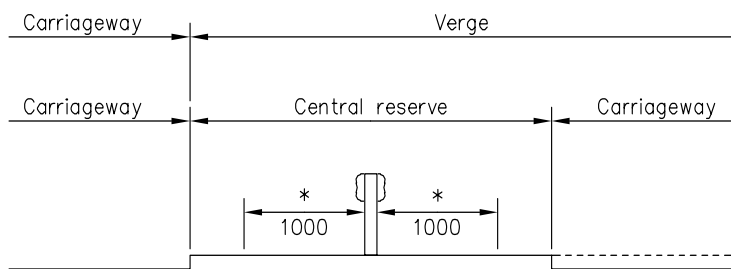

*NOTE: RESTRICTED ZONE
Street Authority to be consulted prior to work commencing

Fig 11  
TYPICAL SAFETY FENCE  
Not to scale



**Annex 2**

**Example of Consultation Form for Special Engineering Difficulty**

**UNDERTAKER**

.....

**FACSIMILE TRANSMISSION**  
**NEW ROADS AND STREET WORKS ACT 1991**

To..... From.....  
.....  
.....  
.....  
Tel No ..... Tel No .....  
Fax No ..... Fax No .....

File Ref .....  
Contact..... Contact .....  
(if known)  
DATE .....

**PRELIMINARY CONSULTATION Relating to proposed works in Streets with Special Engineering Difficulty (section 63 & Schedule 4) or in the vicinity of Highway Structures (in the case of bridges, section 88)**

**LOCATION**

.....

Plan Attached YES/NO\* (Please attach whenever possible)  
Plan No .....  
Road Name/Number .....  
OS Reference .....  
Bridge/Structure No .....

**DESCRIPTION OF PROPOSED WORKS**

.....

.....

New/Renewal/Refurbishment\* Major/Standard/Minor\*  
Size and Type

.....

Proposed depth of excavation

.....

Proposed depth of cover to service on completion

.....

Expected start of works

.....

**BRIDGE AUTHORITY RESPONSE**

File Ref .....

Please contact ..... Tel No .....

Consent to proceed granted/not granted subject to\*  
.....  
.....

Trial Holes required YES/NO\*

Other.....

Additional details required (eg Plans, Sections, Method Statements):  
.....  
.....  
.....

\*Delete as appropriate

Signature .....

Bridge Authority to respond within 7 working days of receipt

Date.....

## APPENDIX E: CO-ORDINATION SCHEDULES

The co-ordination of works over longer periods is aided by the exchange of forward planning information. An EToN message type has been developed for sending forward planning information - this can be found in the Technical Specification for EToN.

Alternatively, promoters can send forward planning information about works electronically using the format in Table 2 below. Information should be provided in the order shown with the fields forming a horizontal row. The highway authority may need to reorder data before converting it into a CSV file for entry into the register. The six-digit grid reference number is important for providing reasonably accurate information on location of works.

	Guidance notes. (Do not include guidance notes in spreadsheet)
Street authority	
Operational district	
Works promoter	
Date of last update	If applicable
Works promoters reference	If applicable
Town	
Locality	
USRN	
Street name	
Road number*	Road classification number
Grid reference (Easting)	Approximately the centre point of the proposed works
Grid reference (Northing)	Approximately the centre point of the proposed works
Works promoter contact name	Name of person who can answer queries regarding the works.
Works promoter contact number	Telephone number of above
Works description	
Works position	When known. Carriageway = C. Footway = F. Verge = V.
Traffic management type	When known
Length of works	When known
Width of works	When known
Start date of works	This may be just a financial or calendar year
End date of works	This may be just a financial or calendar year
Notes	
*Road classification provides works co-ordinators with information on a route basis.	

# APPENDIX F: CENTRAL REGISTERS

## F.1 Data formats

The format of data transferred to a central register from a participating street authority is as described in Technical Specification for EToN i.e. the files sent to the register authority will be an exact copy of the file received or sent by the street authority from or to an undertaker or permit applicant. It will also be the responsibility of the participating street authority to send to the central register copies of all the files relating to their own works, street works licences and such other information required under the central register regulations.

## F.2 Data transfer arrangements - Local Registers

The following diagram describes the flow of information where a local register is in operation.

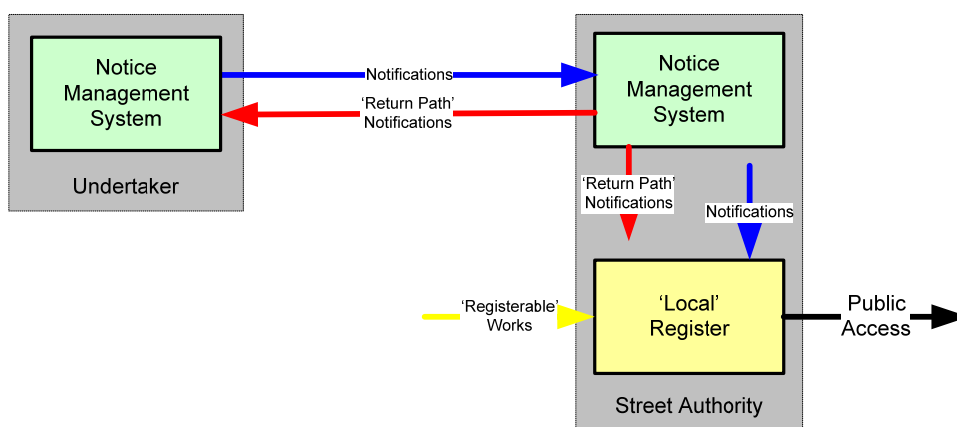

## F.3 Data transfer arrangements – Central Registers

The following diagram describes the flow of information where a central register is in operation.

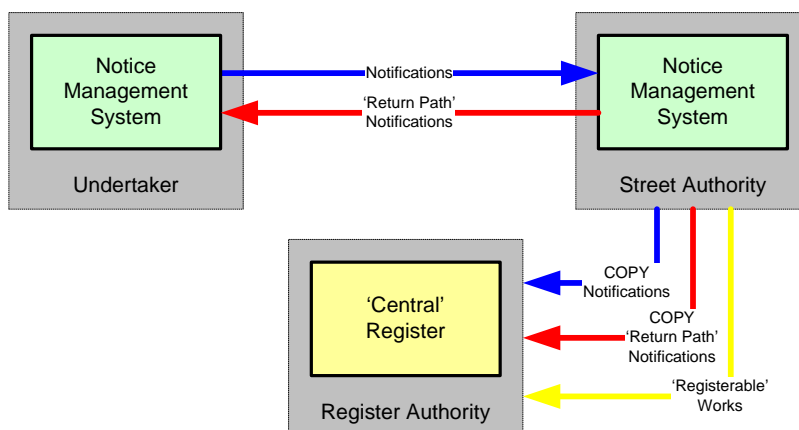

# APPENDIX G: DERIVATION OF DISRUPTION EFFECT SCORE

## G.1 Input Factors

The disruption effect score is based on the reduction in capacity resulting from an activity on the highway. The reduction in capacity may be calculated using an algorithm that requires the entry of a number of simple factors. These factors are as follows:

Factor	Description
[P]	The daily traffic flow, measured as an average am/pm peak hour flow in PCUs per hour, so that it takes account of HGV percentages. Source: Highway authority
[W]	The total width in metres of the carriageway (or the width of both carriageways for a dual carriageway road). Source: Ordnance Survey mapping using GIS tools
[S]	The width in metres of the activity occupying the carriageway, or in the case of activities on the footway, this would be the width in metres of the carriageway occupied by attendant vehicles and associated traffic management, as well as the width needed for any incursion of pedestrians, cyclists and horse riders into the carriageway. Source: Established as part of the works planning process

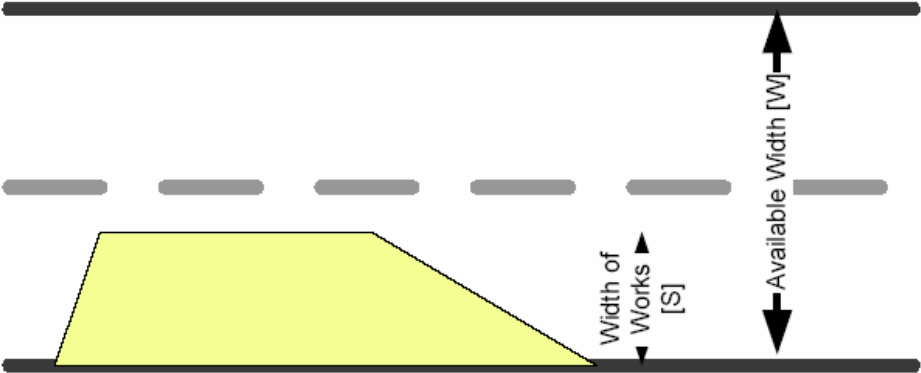

## G.2 Calculation of Disruption Effect Score

The following algorithm is used to calculate the Disruption Effect Score:

$$\text{Disruption Effect Score} = [(P \times 100) / (1600 \times (W - S) / 3.65)]$$

## G.3 Use of Disruption effect Score

The disruption effect score has a number of specific uses including:

- i) Derivation of the Traffic Impact Assessment,
- ii) Objective based prioritisation of activities for co-ordination, and,
- iii) Performance indicators.

However, this is not a mandatory requirement.

## G.4 Impact Assessment

The impact assessment is a broad indicator of the potential disruption that could arise from an activity on the highway.

### G.4.1 Impact on General Traffic

The impact assessment for general traffic is derived directly from the daily disruption effect score for the activities, as follows:

Disruption Effect Score	Impact
Greater than or equal to 75	Severe
Greater than or equal to 50 and less than 75	Moderate
Greater than or equal to 25 and less than 50	Slight
Less than 25	None

### G.4.2 Impact on Buses

The impact assessment for bus traffic is assessed for defined bus routes only and is derived as follows:

Disruption Effect Score / Factor	Impact
Greater than or equal to 75	Severe
Dedicated bus lane closed	Severe
Greater than or equal to 50 and less than 75	Moderate
Dedicated bus lane diverted	Moderate
Greater than or equal to 25 and less than 50	Slight
Less than 25	None

### G.4.3 Impact on Pedestrians

The impact assessment for pedestrian traffic is derived as follows:

Factor	Impact				
	Footway Hierarchy Category				
	1a	1	2	3	4
Closure	Severe	Severe	Severe	Severe	Moderate
Complete Diversion	Severe	Severe	Severe	Moderate	Slight
Partial Diversion	Severe	Severe	Moderate	Moderate	Slight
Narrowing >50%	Severe	Severe	Slight	Slight	None
Narrowing <50%	Severe	Moderate	Slight	None	None

A 'complete diversion' of a footway is where a new route for pedestrians has been established, for example where there is a requirement to cross the road to use the opposite footway.

A 'partial diversion' of a footway is where the route for pedestrians is diverted around the activity's site but remains on the same side of the road.

In addition, the impact of any activities on footways associated with urban transport facilities will be considered as 'severe'. For the purposes of this section these are any activities on footways that are within 100 metres of an entrance to a bus, tube, railway or tram station.

# APPENDIX H: FIXED PENALTY NOTICES FORMS

## Table H1: Fixed Penalty Offences

Offence	Brief description	Duties and obligations
An offence under s.54(5)	Failure to comply with duties under s.54	<p>In certain cases prescribed in regulations prescribed periods of advance notice must be given to a street authority by an undertaker proposing to execute street works.</p> <p>Each notice must state the proposed start date on which it is proposed to begin the works and contain the information prescribed in regulations.</p> <p>After giving <b>advance notice under s.54</b>, an undertaker must comply with the requirements prescribed in regulations, or imposed by the street authority. These concern, the provision of information and procedural steps to co-ordinate the works with other proposed works, of any description.</p> <p>If an undertaker who has given advance notice under s.54 has not, before the starting date specified in the notice, given to the street authority a notice under s.55 in respect of the works, he must within such period as may be prescribed in regulations [Regulation 8(3)] give to that authority a notice containing prescribed information.</p>
An offence under s.55(5)	Beginning to execute works in contravention of s.55	<p>In relation to certain types of street works an undertaker must give prescribed periods of <b>advance notice</b> stating the proposed start date and containing information prescribed in regulations.</p> <p>This notice must be given to the street authority, to any other relevant authority, and to any other person having apparatus in the street, which is likely to be affected by the works.</p> <p>The undertaker must not begin the works without notice, or before the end of the notice period, without the consent of those to whom notice is required to be given.</p>
An offence under s.55(9)	Failure to give notice in accordance with s.55(8)	<p>If the <b>notice of starting date</b> ceases to have effect, the undertaker must give a further notice containing such information as may be prescribed in regulations and within the prescribed period.</p> <p>This notice must be given to the same people as the notice of starting date (<i>see above</i>).</p>
An offence under s.57(4)	Failure to give notice in accordance with s.57	<p>Where emergency works are of a kind which either do, or would, but for certain provisions in Schedule 3A NRSWA, require a <b>notice of starting date</b> under s.55, an undertaker executing such works must give notice stating his intention or, as the case may be, the fact that he has begun to execute the works.</p> <p>The notice must also contain such other information as may be prescribed in regulations.</p> <p>The notice must be given as soon as reasonably practicable, and in any event within two hours (or such other period as may be prescribed), to the persons to whom a notice of starting date would be required to be given under s.55 (<i>see above</i>).</p>
An offence under s.70(6) consisting of a failure to comply with subsection (3) or (4A)	Failure to comply with requirements to give notice of completion of reinstatement	<p>S.70 (1) imposes a general duty on the undertaker to reinstate the street.</p> <p>The undertaker must within ten working days from the date on which the reinstatement is completed give notice to the street authority of that completion. The notice must state whether the reinstatement is permanent or interim, and give such other information about the reinstatement as may be prescribed in regulations.</p> <p>In the case of an interim reinstatement, the undertaker must within ten working days from the date on which the permanent reinstatement is completed, give notice to the street authority of that completion. The notice must contain such other information about the reinstatement as may be prescribed.</p>



<p>An offence created by regulations made under s.74(7B)</p>	<p>Failure to give a notice required by regulations under s.74 (<i>charge for occupation of the highway where works unreasonably delayed</i>)</p>	<p>The Street Works (Charges for Unreasonably Prolonged Occupation of the Highway) (Wales) Regulations 2008 will create a criminal offence in respect of any failure to give a notice required by the regulations.</p> <p>An undertaker executing street works in a highway, to which these regulations apply must, not later than the end of the day following the day on which the works begin, give the highway authority an “<b>actual start of works notice</b>”. This should confirm the actual start date and specify, by reference to the nationally consistent street gazetteer, the street or streets, in which the works are to be carried out.</p> <p>Once an undertaker has completed interim reinstatement, a written “<b>works clear notice</b>” must be given to the highway authority not later than the end of the day following the day on which the highway was returned fully to public use.</p> <p>An undertaker who has completed permanent reinstatement must give the highway authority a written “<b>works closed notice</b>” not later than the end of the day, following the day on which, the highway was returned fully to public use.</p> <p>If the duration of the works will exceed the prescribed period, a notice shall be given to the highway authority containing an estimate of the likely duration. The estimated duration of works should:</p> <ul style="list-style-type: none"> <li>• for works for initial placing of the apparatus, be given with the application for a licence</li> <li>• for other works (not emergency) be given with the section 55 notice</li> <li>• for emergency works be given as soon as practicable after the works begin.</li> </ul> <p>This estimate is assumed to be agreed by the authority, unless it gives a written notice to the undertaker of its own estimate of a reasonable period for the duration within two days of receiving the undertaker’s estimate.</p> <p>If the duration of the works is exceeds the prescribed period, and is likely to exceed either the period stated in a previous estimate of duration or the period agreed or determined under section 74(2) to be a reasonable period, the undertaker shall give a notice in writing containing an estimate or a revised estimate of duration. This estimate is assumed to be agreed by the authority, unless it gives a written notice to the undertaker written notice of its own estimate of a reasonable period for the duration within two days of receiving the undertaker’s estimate.</p>

**Table H2: Guidance on completing the fixed penalty notice form**

*	<b>FIXED PENALTY NOTICE</b> <b>NEW ROADS AND STREET WORKS ACT 1991</b> (Section 95A and Schedules 4A and 4B) The Street Authority may choose to incorporate its 4-digit Data Capture Code	<b>FIXED PENALTY NOTICE</b> Number: ..... ....
<b>PART A</b>		
Contact Tel No.	Works Ref No. *	Street Authority No. *
(*To be left blank where the offence relates to works in respect of which no notice has been given.)		
<b>TO:</b>	<b>DATE OF THIS NOTICE:</b> .....	
<b>ADDRESS:</b>	dd mm yy	
Undertakers are asked to provide, where possible, an electronic address as well as the postal address. If the undertaker fails to provide a postal address then the fixed penalty notice should be served in accordance with the options set out in the regulations		
<b>OFFENCE CODE:</b> (See Part B) (NB: Only one offence code per fixed penalty notice) .....		
<b>LOCATION:</b>	Actual location of works	Insert relevant offence code from Part B
<b>DATE OF OFFENCE:</b>		
<b>DETAILS OF OFFENCE:</b>		
This box needs to specify reasonable particulars of the circumstances alleged to constitute the offence and should be expanded if required		
<p>1. I am giving you this notice, in accordance with section 95A of, and Schedule 4B to, the New Roads and Street Works Act 1991, to offer you the opportunity of discharging any liability to conviction for this fixed penalty offence by payment of a penalty.</p> <p>2. This means that no legal proceedings will be commenced for the offence if, subject to paragraph 3, the penalty of <b>£120</b> is paid (See Part B for instructions on methods of payment) within the period of <b>36</b> days beginning with the day on which this notice was given. (NB: The street authority may extend this period in any particular case if they consider it appropriate to do so (See paragraph 4(3) of Schedule 4B)).</p> <p>3. Instead of paying the amount referred to in paragraph 2, liability to conviction for the offence may also be discharged if the discounted amount of <b>£80</b> is paid within the period of <b>29</b> days beginning with the day on which this notice was given. (NB: If the last day of this period does not fall on a working day, the period for payment of the discounted amount is extended until the end of the next working day (See Paragraph 5(3) of Schedule 4B)).</p> <p>4. If the discounted amount is not paid within the period set out in paragraph 3, as extended where relevant, liability to conviction for the offence may only be discharged thereafter by payment of the penalty of <b>£120</b> within the period set out in paragraph 2, as extended where considered appropriate. If you then fail to pay the penalty within that period, legal proceedings for the offence may be commenced against you.</p> <p>5. Any representations that you wish to make in relation to this notice may be addressed to _____ at _____ identifying the fixed penalty notice number stated above.</p>		
<b>NAME OF AUTHORISED OFFICER (in block capitals):</b>		
.....		
<b>DATE:</b>		
.....		
<div style="display: flex; justify-content: space-around; margin-top: 20px;"> <div style="border: 1px solid black; padding: 5px; width: 30%;">These should be different officers.</div> <div style="border: 1px solid black; padding: 5px; width: 30%;">Representations in writing should be made to this officer. This may be a named individual or department, but the authority should provide full contact details.</div> </div>		

**PART B**

<p align="center">*</p> <p align="center">(* Insert Street Authority name)</p>	<p><b><u>INSTRUCTIONS ON METHODS OF PAYMENT</u></b></p> <div style="border: 1px solid black; padding: 5px; width: fit-content; margin: 10px auto;">             This must match to the number given in Part A         </div>	<p align="center"><b>FIXED PENALTY NOTICE</b></p> <p align="center">Number: .....</p>
<p><b>ELECTRONICALLY</b> – by the Bankers Automated Clearing Services (BACS). Payment should be made to _____, Sort Code _____, Account Number _____. Payment must be supported by the timely submission of a list of the fixed penalty notice numbers covered by the payment and the amount being paid in relation to each number.</p>		
<p>“ON LINE” - please visit our web site at _____</p> <div style="border: 1px solid black; padding: 2px; width: fit-content; margin: 5px auto;">             'N/A' to be inserted if this method of payment is not available         </div>		
<p><b>BY POST</b> - by making your cheque payable to _____ and sending it to _____. Payment must be accompanied by a list of the fixed penalty notice numbers covered by the payment and the amount being paid in relation to each number. A receipt will be sent on request.</p>		
<p><b>IN PERSON</b> – to _____ at _____ between _____ am and _____ pm on any day on which the office is open for business. Any cheque should be made payable to _____. Payment may be made by debit or credit card if the card is one that is accepted by the Street Authority in accordance with their standard procedures. Payment must be accompanied by a list of the fixed penalty notice numbers covered by the payment and the amount being paid in relation to each number. A receipt will be provided on request.</p>		
<p><b>BY TELEPHONE</b> – by contacting _____ at _____ on _____ between _____ am and _____ pm on any day on which the office is open for business. Payment may only be made by using a debit or credit card that is accepted by the Street Authority in accordance with their standard procedures. You must state the fixed penalty notice number of each notice in respect of which payment is being made and the amount being paid in relation to each number. A receipt will be sent on request.</p>		
<p><b>OTHER METHOD/S</b> - *                  (* Insert details where applicable.)</p>		

<b>OFFENCE CODES AND DESCRIPTION</b>		
<b>(By reference to the New Roads and Street Works Act 1991)</b>		
<b>CODE</b>	<b>OFFENCE</b>	<b>BRIEF DESCRIPTION</b>
<b>01</b>	An offence under section 54(5).	Failure to comply with duties under s.54 (advance notice of certain works, etc.).
<b>02</b>	An offence under section 55(5).	Beginning to execute works in contravention of s.55 (notice of starting date).
<b>03</b>	An offence under section 55(9).	Failure to give notice in accordance with s.55(8) (notice to be given on s.55 notice ceasing to have effect).
<b>04</b>	An offence under section 57(4).	Failure to give notice in accordance with s.57 (notice of emergency works).
<b>05</b>	An offence under section 70(6) consisting of a failure to comply with subsection (3) or (4A).	Failure to comply with requirements to give notice of completion of reinstatement.
<b>06</b>	An offence created by regulations made under section 74(7B).	Failure to give a notice required by regulations under s.74 (charge for occupation of the highway where works unreasonably delayed).

**Table H3: Guidance on withdrawing an FPN.**

This number must be the same as the one given on the FPN form

<p>*</p> <p><i>(* Insert Street Authority name)</i></p>	<p><b>NOTICE WITHDRAWING FIXED PENALTY NOTICE</b></p> <p><b>NEW ROADS AND STREET WORKS ACT 1991</b></p> <p>(Section 95A and Schedules 4A and 4B)</p>	<p><b>FIXED PENALTY NOTICE</b></p> <p>Number:</p> <p>.....</p>
---	--	--

**TAKE NOTICE** that the fixed penalty notice numbered as above is hereby **WITHDRAWN**.

**NAME OF AUTHORISED OFFICER** *(in block capitals)*

.....

**DATE**



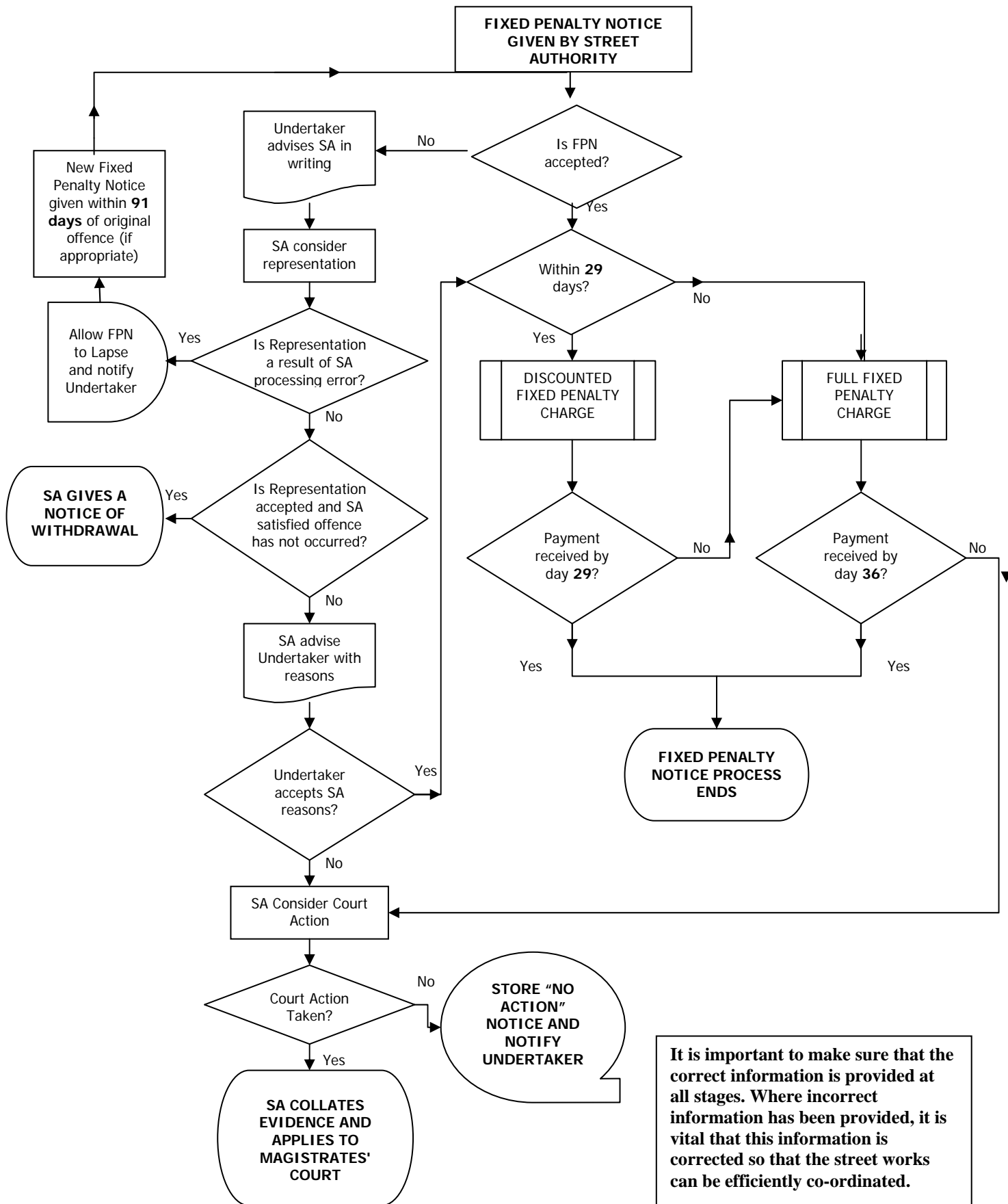

.....

# Fixed Penalty Notice process diagram

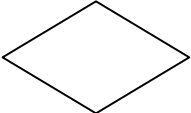

It is important to make sure that the correct information is provided at all stages. Where incorrect information has been provided, it is vital that this information is corrected so that the street works can be efficiently co-ordinated.

## Explanation of chart

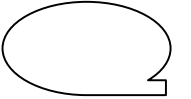
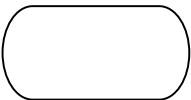
'Allow FPN to lapse'.	If the representations made by the undertaker are on the grounds that the SA had made an error on the FPN but the SA still believes that the grounds for giving the FPN were valid, the SA can allow the 36 day period to pass causing the FPN to 'lapse'. A SA is not able to give two FPNs for the same offence. The SA can then consider giving the FPN with corrected details provided that 91 days have not elapsed since the commission of the offence.
'Store "No Action" Notice'.	If the undertaker refuses to pay the penalty but the SA decides not to commence proceedings in the Magistrates' Court, the SA should file the FPN as a "No Action" notice.
	Process
	Decision
	Document
	Delay
	Predefined process
	Sequential storage
	Terminator

**Table H4: Form of the fixed penalty notice form**

*	<b>FIXED PENALTY NOTICE</b> <b>NEW ROADS AND STREET WORKS ACT 1991</b> (Section 95A and Schedules 4A and 4B)	<b>FIXED PENALTY NOTICE</b> Number: .....
PART A		
Contact Tel No.	Works Ref No. * Street Authority No. * (*To be left blank where the offence relates to works in respect of which no notice has been given.)	
<b>TO:</b>	<b>DATE OF THIS NOTICE:</b> ..... dd mm yy	
<b>ADDRESS:</b>		
<b>OFFENCE CODE:</b> (See Part B) ( <b>NB:</b> Only one offence code per fixed penalty notice) .....		
<b>LOCATION:</b>		
<b>DATE OF OFFENCE:</b>		
<b>DETAILS OF OFFENCE:</b>		
<p><b>1.</b> I am giving you this notice, in accordance with section 95A of, and Schedule 4B to, the New Roads and Street Works Act 1991, to offer you the opportunity of discharging any liability to conviction for this fixed penalty offence by payment of a penalty.</p> <p><b>2.</b> This means that no legal proceedings will be commenced for the offence if, subject to paragraph 3, the penalty of <b>£120</b> is paid (See Part B for instructions on methods of payment) within the period of <b>36</b> days beginning with the day on which this notice was given. (<b>NB:</b> The street authority may extend this period in any particular case if they consider it appropriate to do so (See paragraph 4(3) of Schedule 4B)).</p> <p><b>3.</b> Instead of paying the amount referred to in paragraph 2, liability to conviction for the offence may also be discharged if the discounted amount of <b>£80</b> is paid within the period of <b>29</b> days beginning with the day on which this notice was given. (<b>NB:</b> If the last day of this period does not fall on a working day, the period for payment of the discounted amount is extended until the end of the next working day (See Paragraph 5(3) of Schedule 4B)).</p> <p><b>4.</b> If the discounted amount is not paid within the period set out in paragraph 3, as extended where relevant, liability to conviction for the offence may only be discharged thereafter by payment of the penalty of <b>£120</b> within the period set out in paragraph 2, as extended where considered appropriate. If you then fail to pay the penalty within that period, legal proceedings for the offence may be commenced against you.</p> <p><b>5.</b> Any representations that you wish to make in relation to this notice may be addressed to _____ at identifying the fixed penalty notice number stated above.</p>		
<b>NAME OF AUTHORISED OFFICER</b> (in block capitals): .....		
<b>DATE:</b> .....		

**PART B**

<p align="center">*</p> <p align="center">(* Insert Street Authority name)</p>	<p><b><u>INSTRUCTIONS ON METHODS OF PAYMENT</u></b></p>	<p><b>FIXED PENALTY NOTICE</b></p> <p>Number:</p> <p>.....</p> <p>...</p>
<p><b>ELECTRONICALLY</b>– by the Bankers Automated Clearing Services (BACS). Payment should be made to _____, Sort Code _____, Account Number _____. Payment must be supported by the timely submission of a list of the fixed penalty notice numbers covered by the payment and the amount being paid in relation to each number.</p>		
<p><b>“ON LINE”</b>- please visit our web site at _____.</p>		
<p><b>BY POST</b> - by making your cheque payable to _____ and sending it to _____. Payment must be accompanied by a list of the fixed penalty notice numbers covered by the payment and the amount being paid in relation to each number. A receipt will be sent on request.</p>		
<p><b>IN PERSON</b> – to _____ at _____ between _____ am and _____ pm on any day on which the office is open for business. Any cheque should be made payable to _____. Payment may be made by debit or credit card if the card is one that is accepted by the Street Authority in accordance with their standard procedures. Payment must be accompanied by a list of the fixed penalty notice numbers covered by the payment and the amount being paid in relation to each number. A receipt will be provided on request.</p>		
<p><b>BY TELEPHONE</b> – by contacting _____ at _____ on _____ between _____ am and _____ pm on any day on which the office is open for business. Payment may only be made by using a debit or credit card that is accepted by the Street Authority in accordance with their standard procedures. You must state the fixed penalty notice number of each notice in respect of which payment is being made and the amount being paid in relation to each number. A receipt will be sent on request.</p>		
<p><b>OTHER METHOD/S</b> - * (* Insert details where applicable.)</p>		

**OFFENCE CODES AND DESCRIPTION**

(By reference to the New Roads and Street Works Act 1991)

CODE	OFFENCE	BRIEF DESCRIPTION
<b>01</b>	An offence under section 54(5).	Failure to comply with duties under s.54 (advance notice of certain works, etc.).
<b>02</b>	An offence under section 55(5).	Beginning to execute works in contravention of s.55 (notice of starting date).
<b>03</b>	An offence under section 55(9).	Failure to give notice in accordance with s.55(8) (notice to be given on s.55 notice ceasing to have effect).
<b>04</b>	An offence under section 57(4).	Failure to give notice in accordance with s.57 (notice of emergency works).
<b>05</b>	An offence under section 70(6) consisting of a failure to comply with subsection (3) or (4A).	Failure to comply with requirements to give notice of completion of reinstatement.
<b>06</b>	An offence created by regulations made under section 74(7B).	Failure to give a notice required by regulations under s.74 (charge for occupation of the highway where works unreasonably delayed).



